

# Operating Instructions

**Fronius Tauro 50-3**  
**Fronius Tauro ECO 50-3**  
**Fronius Tauro ECO 99-3**  
**Fronius Tauro ECO 100-3**

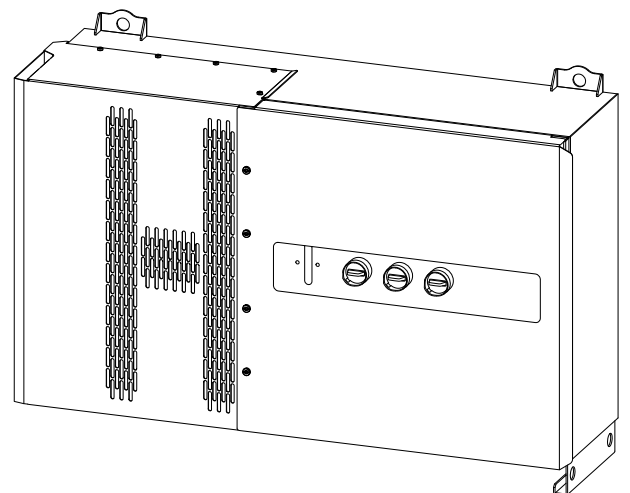

**EN** | Operating Instructions





# Contents

Safety rules.....	6
Explanation of safety notices .....	6
General.....	6
Environmental conditions.....	7
Qualified personnel.....	7
Safety measures at the installation location .....	7
Noise emission values.....	7
EMC measures.....	7
Data protection .....	8
Copyright.....	8
Protective earthing (PE).....	8
Maintenance.....	8
<b>General information</b> .....	<b>9</b>
Description of the device.....	11
Description of the device.....	11
AC Daisy Chain.....	11
String fuses.....	11
Fronius Solar.web .....	12
Local communication .....	13
Protection of people and equipment.....	14
Safety .....	14
Warning notices and rating plate on the device.....	14
WSD (wired shutdown).....	15
Central grid and system protection .....	15
RCMU .....	15
Surge protective device.....	15
Surge protective device (SPD).....	16
AFCI – Arc Fault Circuit Interrupter (ArcGuard).....	16
Safe state.....	17
Proper use.....	18
Intended use.....	18
Regulations governing the photovoltaic system.....	18
Functional principle.....	19
Functional principle.....	19
Cooling of the inverter through forced-air ventilation.....	19
Power derating.....	19
Control elements and connections.....	20
Controls and displays.....	20
PV connections - Tauro 50-3-D (direct).....	20
PV connections - Tauro Eco 50-3-D (direct).....	21
PV connections - Tauro 50-3-D (30A fuses).....	21
PV connections - Tauro Eco 50-3-D (30A fuses).....	21
PV connections - Tauro Eco 99-3-D / 100-3-D (direct, 20 A option).....	22
PV connections - Tauro Eco 99-3-D / 100-3-D (direct, 30 A option).....	22
PV connections - pre-combined .....	22
Mounting option for third-party components .....	23
Data communication area in the inverter.....	23
Data communication area.....	23
Internal schematic connection diagram of the IOs .....	25
Button functions and LED status indicator.....	25
<b>Installation and commissioning</b> .....	<b>29</b>
General.....	31
System component compatibility.....	31
Installation location and position.....	32
Choosing the location of the inverter .....	32
Installation position.....	33

Transport.....	35
Crane transport.....	35
Transporting by counterbalanced lift truck or lift truck.....	35
Mounting the inverter.....	36
Selecting the fixing material.....	36
Mounting bracket dimensions.....	36
Mounting the inverter on the wall.....	36
Mounting the inverter on floor racks.....	38
Connecting the inverter to the public grid (AC side).....	39
Monitoring the grid.....	39
AC connection area.....	39
Connecting aluminium cables.....	40
Permitted cables.....	40
Maximum alternating current fuse protection.....	41
Changing the clamping area for V-type terminal.....	42
Sector conductors at the V-type terminal.....	42
Additional PE introduction for earthing.....	42
Safety.....	43
Opening the inverter.....	44
Switching off the AC disconnecter option.....	44
Connecting the inverter to the public grid - Singlecore.....	44
Connecting the inverter to the public grid - Singlecore with PEN conductor.....	45
Connecting the inverter to the public grid - Multicore.....	47
Connecting the inverter to the public grid - Daisy Chain.....	48
Connecting cables with a cable lug.....	50
Connecting the PV cable to the inverter.....	51
Safety.....	51
General comments regarding PV modules.....	52
Permitted cables.....	52
DC fuse protection - pre-combined.....	53
Example of Fronius Tauro Eco 50-3-P / 99-3-P / 100-3-P combiner box.....	54
Example Fronius Tauro 50-3-P combiner box.....	55
Distribution of the solar module strings for the direct version.....	55
Connecting PV cables - MC4 connector.....	56
MC4 connector cover.....	56
Connecting PV cables - Pre-combined.....	57
Connecting cables with a cable lug.....	58
Replacing the string fuses.....	59
Closing and switching on the inverter.....	61
Connecting the data communication cable.....	63
Modbus participants.....	63
Permitted cables for the data communication area.....	63
Multiple inverters in one network.....	64
Routing data communication cables.....	64
WSD (wired shutdown).....	66
Using for the first time.....	68
Starting the inverter for the first time.....	68
Fronius system monitoring (Pilot) display.....	68
Installation mit der App.....	68
Installation using the web browser.....	69
Switching off current supply and restarting the inverter.....	71
De-energising the inverter and switching it on again.....	71
<b>Settings - user interface of the inverter</b> .....	<b>73</b>
User settings.....	75
User login.....	75
Selecting the language.....	75
Device configuration.....	76
Components.....	76
Functions and IOs.....	76
"PSC editor - AUS - Demand Response Modes (DRM)".....	77

Demand Response Modes (DRM).....	77
Inverter .....	77
System.....	79
General.....	79
Update.....	79
Setup wizard.....	79
Restoring the factory settings.....	79
Event Log.....	79
Information.....	79
License Manager.....	80
Support.....	81
Communication.....	82
Network.....	82
Modbus.....	83
Remote control .....	84
Fronius Solar API.....	85
Internet Services.....	85
Safety and grid requirements.....	86
Country setup.....	86
Requesting inverter codes in Solar.SOS .....	86
Feed-in limitation .....	87
I/O power management.....	88
Connection diagram - 4 relay.....	88
I/O power management settings - 4 relays.....	90
Connection diagram - 3 relay.....	91
I/O power management settings - 3 relays .....	92
Connection diagram - 2 relay.....	93
I/O power management settings - 2 relays .....	94
Connection diagram - 1 relay.....	95
I/O power management settings - 1 relay .....	96
<b>Appendix</b> .....	<b>97</b>
Status codes and remedy.....	99
Status Codes .....	99
Technical data.....	100
Tauro 50-3-D / 50-3-P.....	100
Tauro Eco 50-3-D / 50-3-P.....	102
Tauro Eco 99-3-D / 99-3-P.....	104
Tauro Eco 100-3-D / 100-3-P.....	107
WLAN.....	109
Explanation of footnotes.....	110
Integrated DC disconnect .....	110
Applicable standards and guidelines.....	112
CE mark .....	112
WLAN.....	112
Power failure.....	112
Service, warranty terms and conditions and disposal .....	113
Fronius SOS.....	113
Fronius manufacturer's warranty.....	113
Disposal.....	113

# Safety rules

---

## Explanation of safety notices

### **WARNING!**

**Indicates a potentially hazardous situation.**

- ▶ Death or serious injury may result if appropriate precautions are not taken.
- 

### **CAUTION!**

**Indicates a situation where damage could occur.**

- ▶ If not avoided, minor injury and/or damage to property may result.
- 

### **NOTE!**

**Indicates a risk of flawed results and possible damage to the equipment.**

---

If you see any of the symbols depicted in the "Safety rules" chapter, special care is required.

---

## General

The device has been manufactured in line with the state of the art and according to recognised safety standards. In the event of incorrect operation or misuse, there is a risk of:

- Injury or death to the operator or a third party
  - Damage to the device and other material assets belonging to the operator
- 

All personnel involved in commissioning and maintenance of the device must:

- Be suitably qualified,
  - Have knowledge of and experience in dealing with electrical installations and
  - Read and follow these Operating Instructions carefully.
- 

In addition to the Operating Instructions, all applicable local rules and regulations regarding accident prevention and environmental protection must also be followed.

---

All safety and danger notices on the device:

- Must be kept in a legible state
  - Must not be damaged
  - Must not be removed
  - Must not be covered, pasted or painted over
- 

Only operate the device when all protection devices are fully functional. If the protection devices are not fully functional, there is a risk of:

- Injury or death to the operator or a third party
  - Damage to the device and other material assets belonging to the operator
- 

Any safety devices that are not fully functional must be repaired by an authorized specialist before the device is switched on.

---

Never bypass or disable protection devices.

---

For the location of the safety and danger notices on the device, refer to the chapter headed "Warning notices on the device" in the Operating Instructions for your device.

---

Faults that could compromise safety must be remedied before switching on the device.

---

### **Environmental conditions**

Operation or storage of the device outside the stipulated area will be deemed as not in accordance with the intended purpose. The manufacturer accepts no liability for any damage resulting from improper use.

---

### **Qualified personnel**

The servicing information contained in these Operating Instructions is intended only for the use of qualified service engineers. An electric shock can be fatal. Do not carry out any actions other than those described in the documentation. This also applies to qualified personnel.

---

All cables and leads must be secured, undamaged, insulated, and adequately dimensioned. Loose connections, scorched, damaged or inadequately dimensioned cables and leads must be immediately repaired by authorised personnel.

---

Repair work must only be carried out by authorised personnel.

---

It is impossible to guarantee that bought-in parts are designed and manufactured to meet the demands made on them, or that they satisfy safety requirements. Use only original spare parts (also applies to standard parts).

---

Do not carry out any alterations, installations, or modifications to the device without first obtaining the manufacturer's permission.

---

Components that are not in perfect condition must be changed immediately.

---

### **Safety measures at the installation location**

When installing devices with openings for cooling air, ensure that the cooling air can enter and exit unhindered through the air ducts. Only operate the charger in accordance with the degree of protection shown on the rating plate.

---

### **Noise emission values**

The sound power level of the inverter is specified in the [Technical data](#).

---

The device is cooled as quietly as possible with the aid of an electronic temperature control system; this depends on the amount of converted power, the ambient temperature, the level of soiling of the device, etc.

---

It is not possible to provide a workplace-related emission value for this device because the actual sound pressure level is heavily influenced by the installation situation, the grid quality, the surrounding walls and the properties of the room in general.

---

### **EMC measures**

In certain cases, even though a device complies with the standard limit values for emissions, it may affect the application area for which it was designed (e.g., when there is equipment that is susceptible to interference at the same location, or if the site where the device is installed is close to either radio or television receivers). If this is the case, then the operator is obliged to take action to rectify the situation.

---

**Data protection** The user is responsible for the safekeeping of any changes made to the factory settings. The manufacturer accepts no liability for any deleted personal settings.

---

**Copyright** Copyright of these operating instructions remains with the manufacturer.

---

The text and illustrations are all technically correct at the time of printing. We reserve the right to make changes. The contents of the operating instructions shall not provide the basis for any claims whatsoever on the part of the purchaser. If you have any suggestions for improvement, or can point out any mistakes that you have found in the instructions, we will be most grateful for your comments.

---

**Protective earthing (PE)** Connection of a point in the device, system or installation to earth to protect against electric shock in the event of a fault. When installing the Tauro inverter, the PE connection is mandatory as it is a protection class 1 device. When connecting the PE conductor, ensure that it is secured against accidental disconnection. All points listed under "Connecting the inverter to the public grid (AC side)" must be observed, including the use of washers, screw locks, and nuts with the defined torque.

It must be ensured that when using the strain-relief devices, the ground conductor is the last to be disconnected in the event of a possible failure. When connecting the ground conductor, the minimum cross-section requirements specified by the respective national regulations must be observed. In addition, the minimum cross-section of the PE conductor must be at least half of the phase cross-sections according to the product standard IEC 62109-1, as a cross-section of at least 35 mm<sup>2</sup> (50 kW) or 70 mm<sup>2</sup> (99.99 / 100 kW) must be used for the phases (L1 / L2 / L3).

---

**Maintenance** In principle, Tauro inverters are maintenance-free. If maintenance work is nevertheless carried out on the inverter, such as cleaning or replacing components, this must be done in consultation with a Fronius-trained service technician. The manufacturer accepts no liability for damage caused by improper use.

# **General information**



# Description of the device

## Description of the device

The inverter transforms the direct current generated by the solar modules into alternating current. This alternating current is fed into the public grid synchronously with the grid voltage.

The inverter has been developed exclusively for use in grid-connected photovoltaic systems; it is impossible to generate energy independently of the public grid.

Thanks to its design and the way it works, the inverter is extremely safe both to install and to operate.

The inverter automatically monitors the public grid. In the event of abnormal grid conditions, the inverter ceases operating immediately and stops feeding power into the grid (e.g. if the grid is switched off, if there is an interruption, etc.).

The grid is monitored by monitoring the voltage, frequency and islanding conditions.

## AC Daisy Chain

With the "AC Daisy Chain" inverter version, the AC lead can be fed directly from the inverter to another inverter. Several Tauro inverters, up to an output power of max. 200 kW, can be thereby quickly connected to one another.

The minimum cable cross-section is defined by the fuse at the mains connection point. A larger cable cross-section can be selected at any time. The applicable national standards must be taken into account and applied.

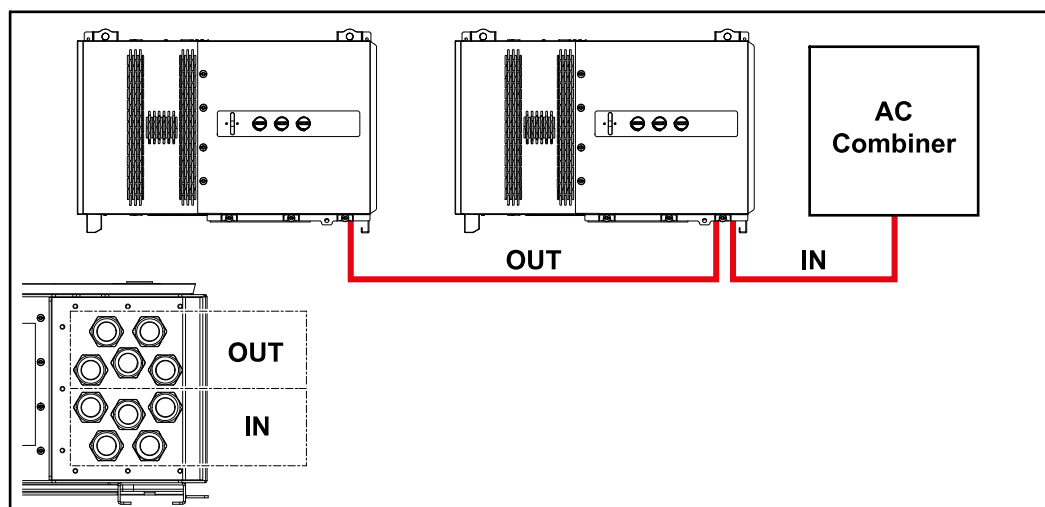

## String fuses

**Only applies to device types Fronius Tauro 50-3-D / Eco 50-3-D / Eco 99-3-D / Eco 100-3-D (direct):**

String fuses are used in the Fronius Tauro to provide additional protection for the solar modules.

The maximum short circuit current  $I_{SC}$ , the maximum module return current  $I_R$  or the maximum string fuse rating specified in the module data sheet of the respective solar module is crucial in affording the solar modules the correct fuse protection.

The national regulations regarding fuse protection must be observed. The electrical engineer carrying out the installation is responsible for the correct choice of string fuses.

To replace the string fuses, see chapter [Replacing the string fuses](#) on page 59.

**Eco 50-3-D**  
**Eco 99-3-D / Eco 100-3-D Standard**  
 F1.1 - F2.7

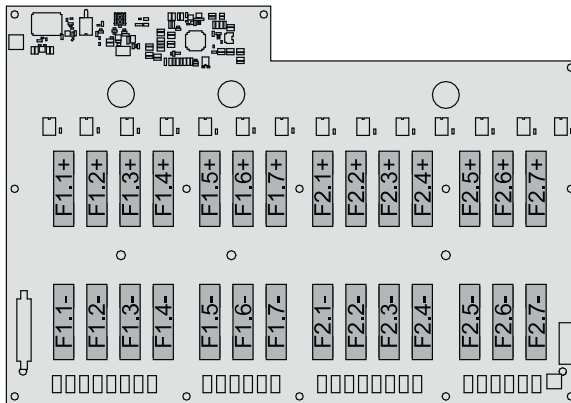

**Eco 99-3-D / Eco 100-3-D**  
**Standard**  
 F3.1 - F3.8

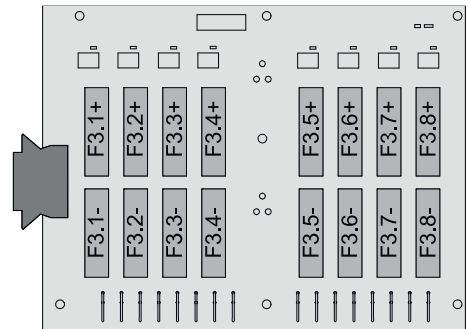

**50-3-D**  
 F1.1 - F3.7

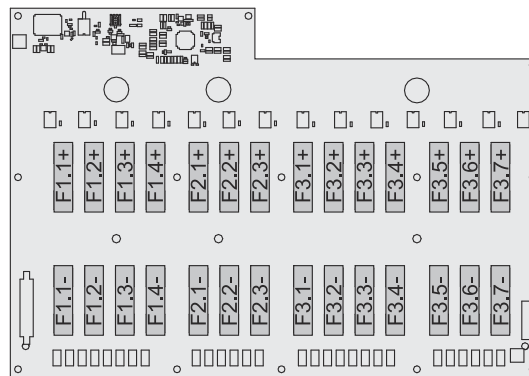

**Eco 50-3-D**  
**30A fuses F1.1 - F2.5**

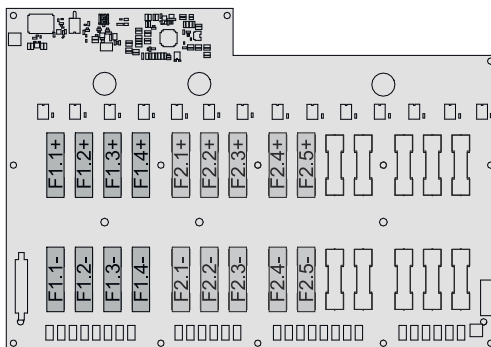

**50-3-D / Eco 99-3-D / Eco 100-3-D**  
**30A fuses F1.1 - F3.5**

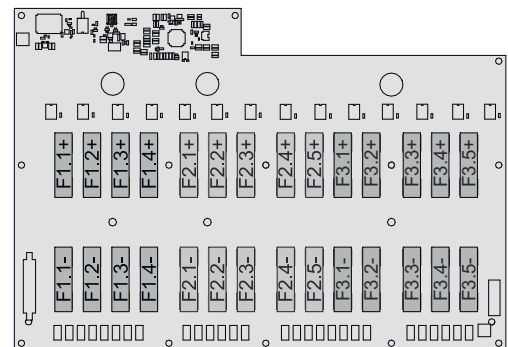

## Fronius Solar.web

With Fronius Solar.web or Fronius Solar.web Premium, the PV system can be easily monitored and analysed by the system owner and installer. If configured accordingly, the inverter transmits data such as power, yields, load, and energy balance to Fronius Solar.web. For more information see [Solar.web - monitoring & analysis](#).

Configuration is carried out via the setup wizard, see chapter [Installation mit der App](#) on page 68 or [Installation using the web browser](#) on page 69.

**Prerequisites for configuration:**

- Internet connection (download: min. 512 kBit/s, upload: min. 256 kBit/s)\*.
- User account on [solarweb.com](https://solarweb.com).
- Completed configuration via the setup wizard.

\* The information given does not constitute an absolute guarantee of faultless function. High error rates in the transmission, reception fluctuations or transmission drop-outs can have a negative effect on the data transfer. Fronius recommends testing the Internet connection on site according to the minimum requirements.

---

**Local communication**

The inverter can be found via the Multicast DNS protocol (mDNS). It is recommended to search for the inverter by the assigned host name.

The following data can be retrieved via mDNS:

- NominalPower
- Systemname
- DeviceSerialNumber
- SoftwareBundleVersion

# Protection of people and equipment

## Safety

### **WARNING!**

#### **Danger due to incorrect operation and incorrectly performed work.**

This can result in serious injury and damage to property.

- ▶ All the work and functions described in this document must only be carried out by trained and qualified personnel.
- ▶ Read and understand this document.
- ▶ Read and understand all the Operating Instructions for the system components, especially the safety rules.

### **WARNING!**

#### **Danger from electromagnetic fields. Electromagnetic fields are generated during operation.**

Effects on the health of persons, e.g. those wearing a pacemaker can result.

- ▶ Do not remain closer than 20 cm from the inverter for a prolonged period of time.

## Warning notices and rating plate on the device

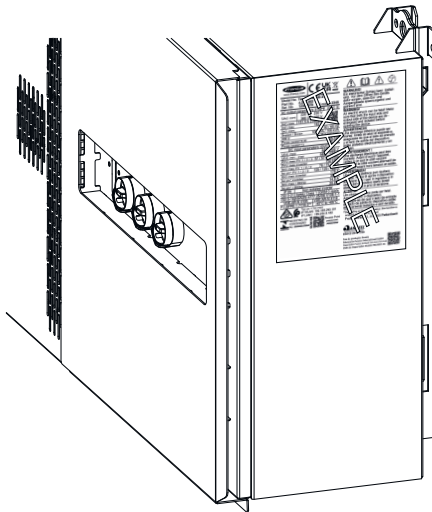

There are warning notices and safety symbols on and in the inverter. These warning notices and safety symbols must not be removed or painted over. They warn against incorrect operation, as this may result in serious injury and damage.

### Symbols on the rating plate:



CE mark – confirms compliance with applicable EU directives and regulations.



UKCA mark – confirms compliance with applicable UK directives and regulations.



WEEE mark – waste electrical and electronic equipment must be collected separately and recycled in an environmentally sound manner in accordance with the European Directive and national law.



RCM mark – tested in accordance with the requirements of Australia and New Zealand.



ICASA mark – tested in accordance with the requirements of the Independent Communications Authority of South Africa.



CMIM mark – tested in accordance with IMANOR requirements for import regulations and compliance with Moroccan standards.

#### Safety symbols:



Risk of serious injury and property damage due to incorrect operation.



Do not use the functions described here until you have fully read and understood the following documents:

- These Operating Instructions.
- All Operating Instructions for the system components of the photovoltaic system, especially the safety rules.



Dangerous electrical voltage.



Before opening the machine, wait for the capacitors to discharge!

#### Text of the warning notices:

##### **WARNING!**

An electric shock can be fatal. Before opening the device, ensure that the input and output sides are de-energised and insulated.

#### **WSD (wired shutdown)**

The wired shutdown (WSD) interrupts the inverter feeding energy into the grid if the trigger device (switch, e.g. emergency stop or fire alarm switch) has been activated.

If an inverter (secondary device) fails, it is bypassed and the other inverters continue operating. If a second inverter (secondary device) or the inverter (primary device) fails, the operation of the entire WSD chain is interrupted.

For installation, see [WSD \(wired shutdown\)](#) on page **66**.

#### **Central grid and system protection**

The inverter offers the option to use the integrated AC relays as coupling switches in conjunction with a central grid and system protection unit (in accordance with VDE-AR-N 4105:2018:11 §6.4.1). For this purpose, the central trigger device (switch) must be integrated into the WSD chain as described in the chapter "WSD (Wired Shut Down)".

#### **RCMU**

The inverter is equipped with a universal current-sensitive residual current monitoring unit (RCMU = Residual Current Monitoring Unit) in accordance with IEC 62109-2 and IEC63112.

This device monitors residual currents from the PV module to the AC output of the inverter and disconnects the inverter from the grid in the event of unauthorised residual current.

#### **Surge protective device**

The inverter is equipped with an integrated surge protective device on the DC and AC side in accordance with IEC 62109-2. The surge protective device protects the system against damage in the event of a surge.

---

## Surge protective device (SPD)

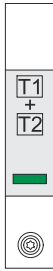

The surge protective device (SPD) protects against temporary over-voltages and dissipates surge currents (e.g. lightning strike). Building on an overall lightning protection concept, the SPD helps to protect your PV system components.

If the surge protective device is triggered, the colour of the indicator changes from green to red (mechanical display).

A tripped SPD must be replaced immediately by an authorised specialist company with a functioning SPD in order to maintain the full protective function of the unit.

There is the option of a digital indication when an SPD has tripped. For setting this function, see PDF "Temporary SPD Triggering" in the Service & Support area at [www.fronius.com](http://www.fronius.com)

### **IMPORTANT!**

After setting the function described above, the inverter will also respond if the 2-pole signal cable of the surge protective device is interrupted or damaged.

---

## AFCI – Arc Fault Circuit Interrupter (Arc-Guard)

Available ex works.

AFCI (Arc Fault Circuit Interrupter) protects against arcing faults and in the narrower sense is a protection device against contact faults. The AFCI evaluates any faults that occur in the current and voltage curve with an electronic circuit and switches off the circuit when a contact fault is detected. This prevents overheating on poor contacts and possible fires.

### **IMPORTANT!**

Active solar module electronics can interfere with the function of the ArcGuard. Fronius does not guarantee the correct functioning when using Fronius ArcGuard in combination with active solar module electronics.



### **CAUTION!**

#### **Danger due to incorrect or unprofessional DC installation.**

This can result in risk of damage and, in turn, risk of fire to the PV system due to inadmissible thermal loads that arise with an arc.

- ▶ Check that plug connections are in good condition.
- ▶ Repair incorrect insulation as appropriate.
- ▶ Complete connections as per the specifications.

---

### **IMPORTANT!**

Fronius will not accept any costs associated with production downtimes, installer costs, etc., that may arise as the result of a detected arc and its consequences. Fronius accepts no liability for damage that can occur despite the presence of the integrated Arc Fault Circuit Interrupter/extinguishing system ( e.g. caused by a parallel arc).

#### **Automatic reconnection**

To restart the AFCI, no manual procedure is required if a minimum interruption time of 5 minutes is ensured before continuing operation.

When interrupting for the fifth time within a 24 h period, the AFCI is only allowed to be reset manually before the AFCI does reconnect. Afterwards, the AFCI may return to automatic reconnection mode.

---

**Safe state**

If one of the following safety devices trips, the inverter will change to a safe state:

- WSD
- isolation measurement
- RCMU and
- AFCI

In the safe state, the inverter no longer feeds into the grid and is disconnected from the grid by opening the AC relays.

# Proper use

---

## **Intended use**

The solar inverter is intended exclusively to convert direct current from solar modules into alternating current and to feed this into the public grid.

Utilisation not in accordance with the intended purpose comprises:

- Utilisation for any other purpose, or in any other manner
- Making any modifications to the inverter that have not been expressly approved by Fronius
- Installation of parts that are not distributed or expressly approved by Fronius

The manufacturer shall not be liable for any damage resulting from such use. All warranty claims will be forfeited.

Intended use also includes complying with all the instructions in the Operating Instructions.

---

## **Regulations governing the photovoltaic system**

The inverter is designed to be connected and used exclusively in conjunction with solar modules.

Use of the inverter with other DC generators (e.g. wind generators) is not permitted.

When designing the photovoltaic system, ensure that all of its components are operated within their permitted operating ranges at all times.

Observe all the measures recommended by the solar module manufacturer to ensure that the solar module retains its properties in the long term.

# Functional principle

---

## Functional principle

The inverter operates fully automatically. As soon after sunrise as there is sufficient energy available from the solar modules, the inverter starts checking the PV system (insulation measurement), and the grid (grid voltage and grid frequency). If all values are within the normative scope, automatic connection to the grid and feeding of energy into the grid takes place.

The inverter works in a way that ensures the maximum power possible is obtained from the solar modules. This is known as "Maximum Power Point Tracking" (MPPT). In the event of shading of the solar modules, the function "Dynamic Peak Manager" can be used to obtain the majority of the local maximum output (LMPP) of the PV system.

After dusk, as soon as the power available has fallen below the level at which energy can be fed into the grid, the inverter disconnects the power electronics completely from the grid and stops running. It retains all its settings and stored data.

---

## Cooling of the inverter through forced-air ventilation

Cooling of the inverter is performed by a forced-air ventilation system via temperature-controlled fans. Air is sucked in from the front and fed, via a sealed duct, through the AC and DC heat sink, before passing directly over the inductors and dissipating.

The sealed air duct prevents the electronics compartment from coming into contact with the ambient air. This approach largely prevents any contamination of the electronics compartment.

The fan speed and temperature of the inverter are monitored.

The variable-speed, ball-bearing mounted fans in the inverter permit the following:

- Optimum cooling of the inverter
  - Cooler components, therefore a longer service life
  - Lowest-possible energy consumption
  - High output power including in top temperature range of the inverter
- 

## Power derating

If the inverter becomes too hot, it automatically reduces the current output power in order to protect itself. Reasons for the inverter becoming too hot include too high an ambient temperature or inadequate heat dissipation (e.g. when installed in containers without proper heat dissipation measures).

A power derating system restricts the output from the inverter in order to prevent the temperature from exceeding the permissible value.

If a maximum temperature is exceeded, the inverter switches off in a safe state and does not resume feeding energy into the grid until the device has cooled down.

# Control elements and connections

## Controls and displays

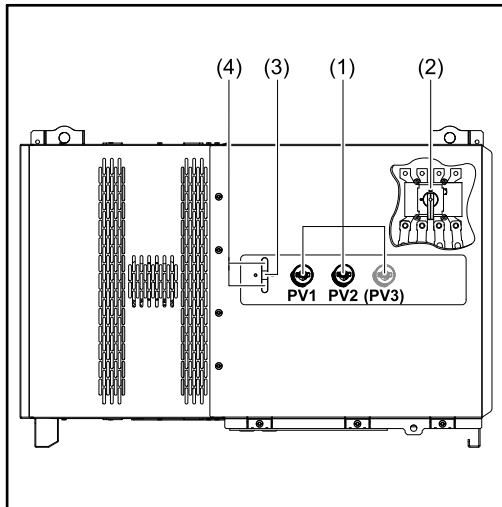

- (1) **DC disconnect**  
Disconnects the electrical connection from the solar modules to the inverter. Depending on the device type, 2 or 3 DC disconnectors are installed. The DC disconnectors can be secured against switching on with a padlock.
- (2) **AC disconnect option**  
The optional AC disconnector breaks the connection from the inverter to the grid
- (3) **Button function**  
For further information about the button function, see [Button functions and LED status indicator](#)
- (4) **LED status indicator**  
For further information about the LED status indicator, see [Button functions and LED status indicator](#)

## PV connections - Tauro 50-3-D (direct)

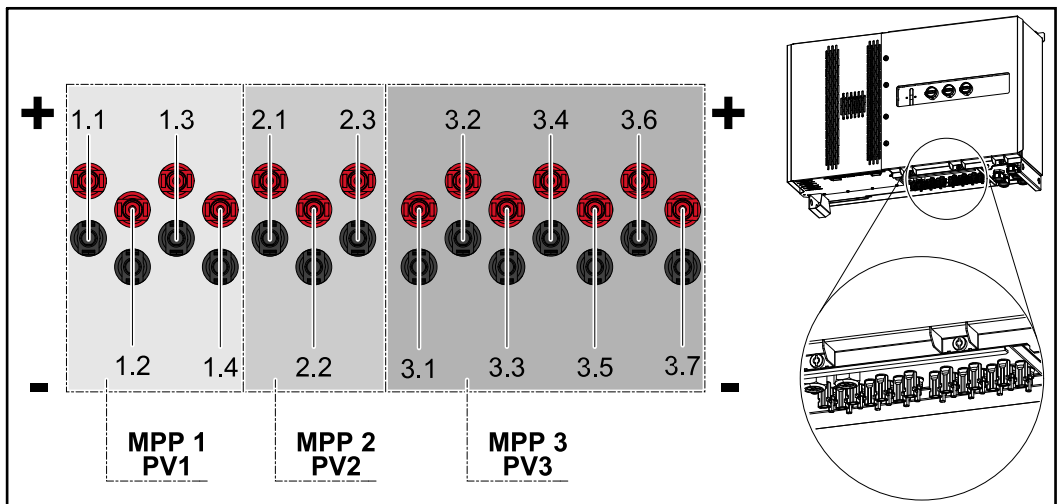

**PV connections -  
Tauro Eco 50-3-  
D (direct)**

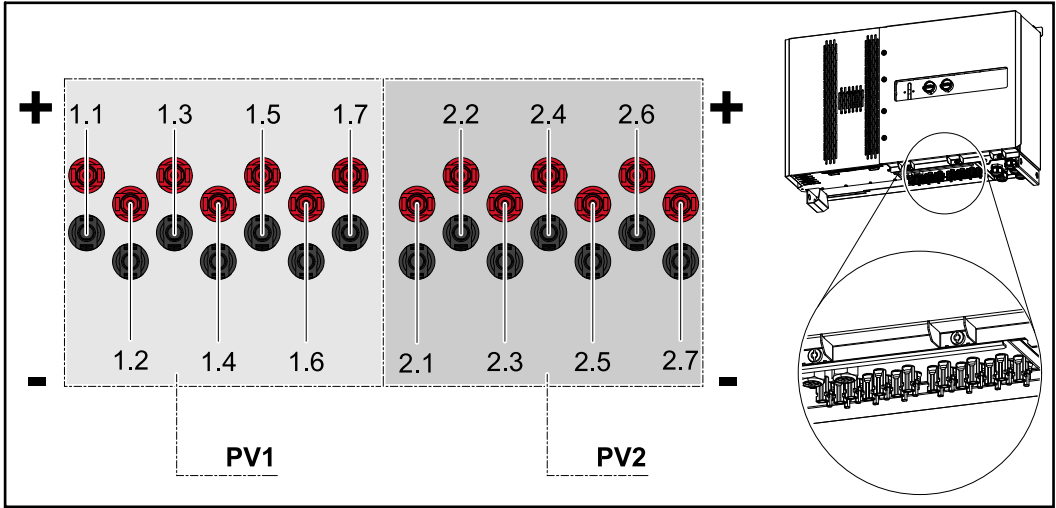

**PV connections -  
Tauro 50-3-D  
(30A fuses)**

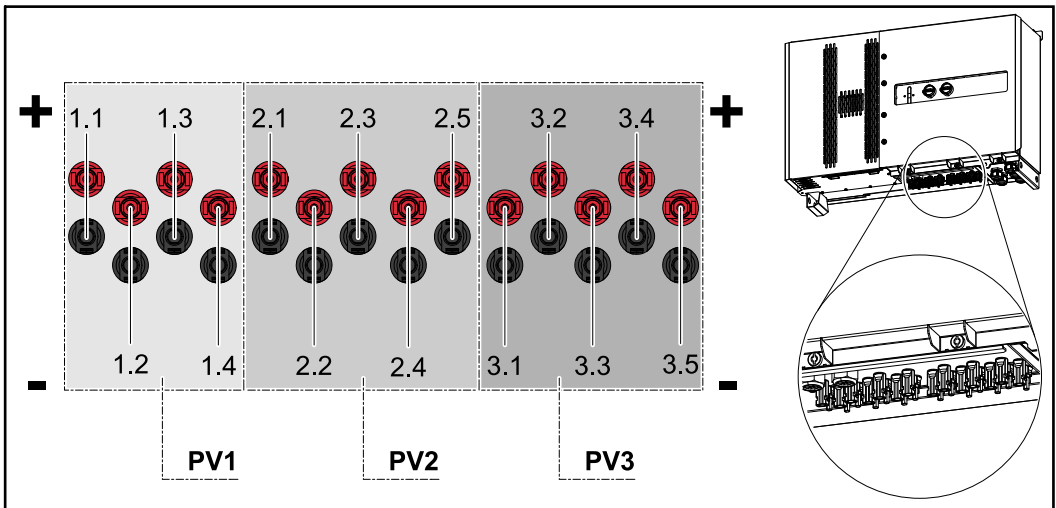

**PV connections -  
Tauro Eco 50-3-  
D (30A fuses)**

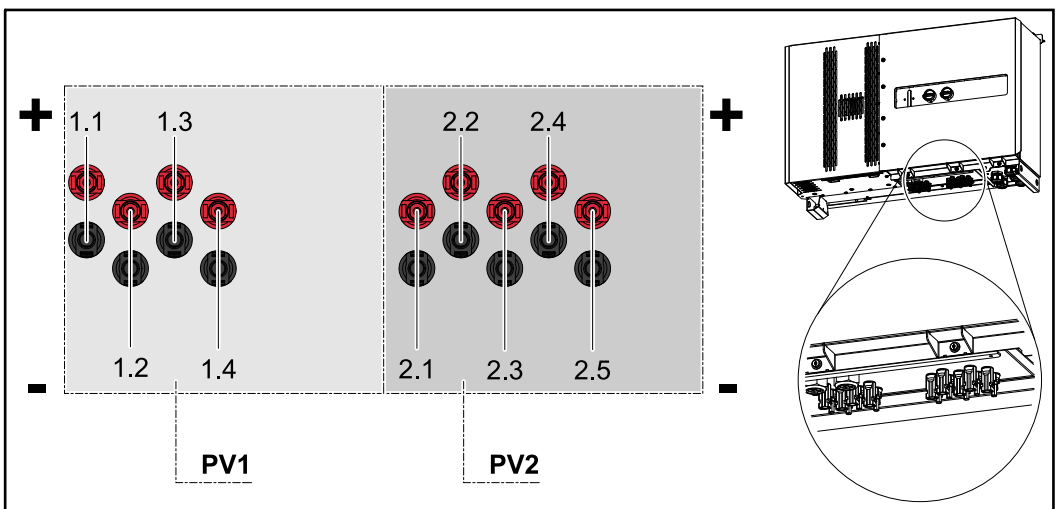

**PV connections -  
Tauro Eco 99-3-  
D / 100-3-D (dir-  
ect, 20 A option)**

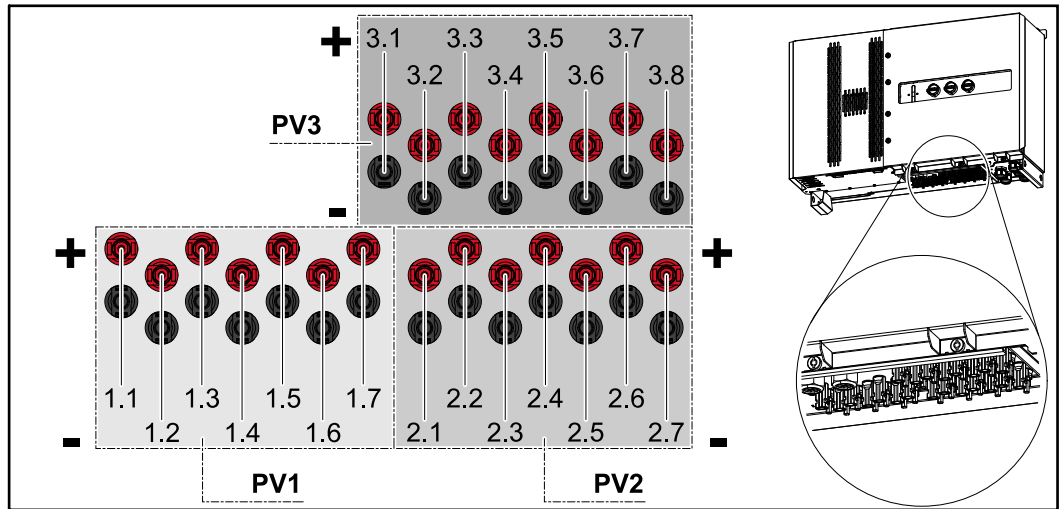

**PV connections -  
Tauro Eco 99-3-  
D / 100-3-D (dir-  
ect, 30 A option)**

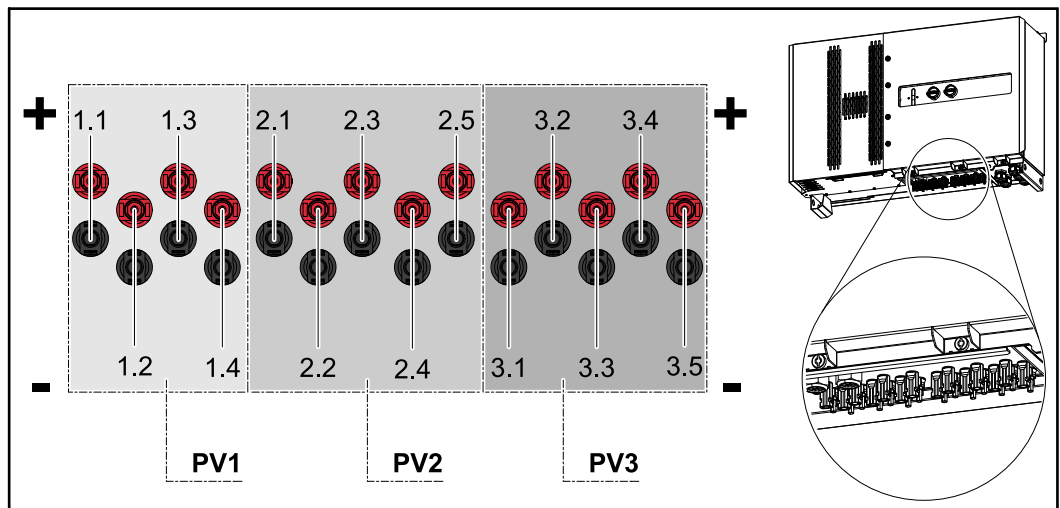

**PV connections -  
pre-combined**

Tauro Eco 50-3-P / 99-3-P / 100-3-P

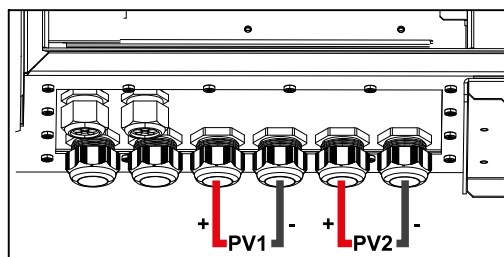

Tauro 50-3-P

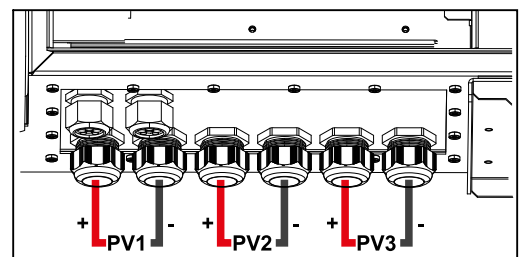

**Mounting option for third-party components**

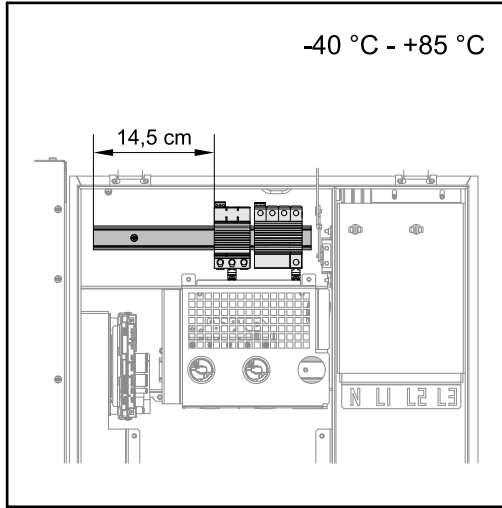

Above the DC connection area there is space for mounting third-party components. Components up to a maximum width of 14.5 cm (8 DU) can be mounted on the DIN rail. The components must have a temperature resistance of -40 °C to +85 °C.

**Data communication area in the inverter**

The data communication area (Pilot PC board) is located above the DC connections in the inverter.

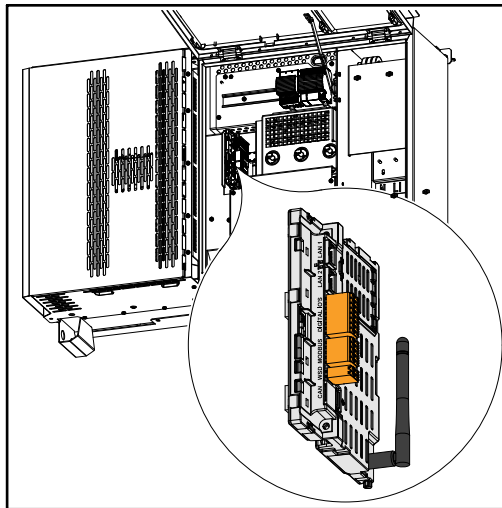

**Data communication area**

**LED**

**Battery \***

**WSD**

**Modbus 0** Terminating resistor

**Modbus 1** Terminating resistor

**LED**

**Technical Data (WLAN)**  
 Frequency band: channel 1-14(2412-2462 MHz)  
 Radio-frequency power: <100 mW (<20 dBm)  
**IP WLAN: 192.168.250.181 | Password: 12345678**

**Battery \* Connection**

**Modbus**

**WSD**

**LAN 1** → IP: 169.254.0.180

**LAN 2** → Reserved for internal use



**I/Os**

**Modbus**  
 GND M0+ SHIELD M1+ V+  
 RS485 (0/1) → Fronius Smart Meter, Ohmpilot, Battery (only GEN24), Sunspec, Interface ...

**WSD**  
 IN- OUT-  
 Factory default  
 WSD > wired disconnection at grid feed-in

**I/Os**  
 GND V+ IO0 IO2 IO4\* IO6\* IO8\* IO9\* IO10  
 IO1 IO3 IO5\* IO7\* IO11  
 \* Demand Response Mode (DRM)  
 IO4 = RG0 (Ref GEN/0)  
 IO5 = CL0 (COM LOAD/0)  
 IN6 = 1/5  
 IN7 = 2/6  
 IN8 = 3/7  
 IN9 = 4/8

\*Not in use

 <b>Operating status LED</b>	Indicates the inverter operating status.
<b>WSD (wired shutdown) switch</b>	Defines the inverter as a WSD primary device or WSD secondary device.  <b>Position 1:</b> WSD primary device <b>Position 0:</b> WSD secondary device
<b>Modbus 0 (MBO) switch</b>	Switches the terminating resistor for Modbus 0 (MBO) on/off.  <b>Position 1:</b> Terminating resistor on (factory setting) <b>Position 0:</b> Terminating resistor off
<b>Modbus 1 (MB1) switch</b>	Switches the terminating resistor for Modbus 1 (MB1) on/off.  <b>Position 1:</b> Terminating resistor on (factory setting) <b>Position 0:</b> Terminating resistor off
 <b>Optical sensor</b>	To operate the inverter. See chapter <a href="#">Button functions and LED status indicator</a> on page 25.
 <b>Communication LED</b>	Indicates the inverter connection status.
<b>LAN 1</b>	Ethernet connection for data communication (e.g. WLAN router, home network or for commissioning with a laptop see chapter <a href="#">Installation using the web browser</a> on page 69).
<b>LAN 2</b>	Reserved for future functions. Only use LAN 1 to avoid malfunctions.
<b>I/Os terminal</b>	Push-in terminal for digital inputs/ outputs. See chapter <a href="#">Permitted cables for the data communication area</a> on page 63. The designations (RGO, CLO, 1/5, 2/6, 3/7, 4/8) on the terminal refer to the Demand Response Mode function, see chapter <a href="#">"PSC editor - AUS - Demand Response Modes (DRM)"</a> on page 77.
<b>WSD terminal</b>	Push-in terminal for the WSD installation. See chapter <a href="#">"WSD (wired shutdown)"</a> on page 15.
<b>Modbus terminal</b>	Push-in terminal for the installation of Modbus 0, Modbus 1, 12 V and GND (ground).  The data connection to the connected components is established via the Modbus terminal. <b>The inputs M0 and M1 can be selected for this purpose.</b> Max. 4 Modbus participants per input, see chapter <a href="#">Modbus participants</a> on page 63.

**Internal schematic connection diagram of the IOs**

On the V+/GND pin, it is possible to feed in a voltage of around 12.5–24 V (+ max. 20%) with an external power supply. The outputs IO 0–5 can then be operated with the external voltage. A maximum of 1 A can be drawn per output, with a maximum of 3 A allowed in total. The fuse protection must be located externally.

**⚠ CAUTION!**

**Risk of polarity reversal at the terminals due to improper connection of external power supplies.**

This may result in severe damage to the inverter.

- ▶ Check the polarity of the external power supply with a suitable measuring device before connecting it.
- ▶ Connect the cables to the V+/GND outputs with the correct polarity.

**IMPORTANT!**

If the total output (6 W) is exceeded, the inverter switches off the entire external power supply.

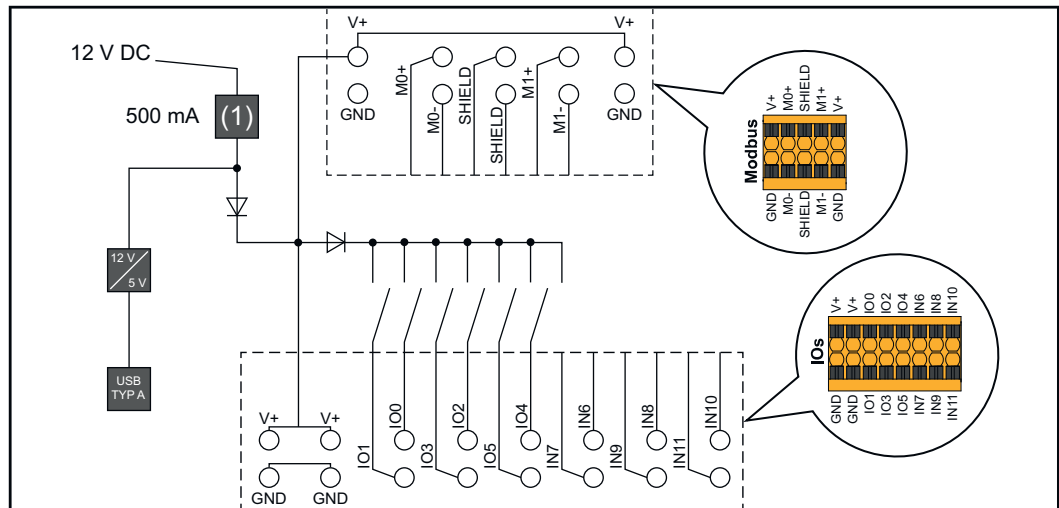

(1) Power limitation

**Button functions and LED status indicator**

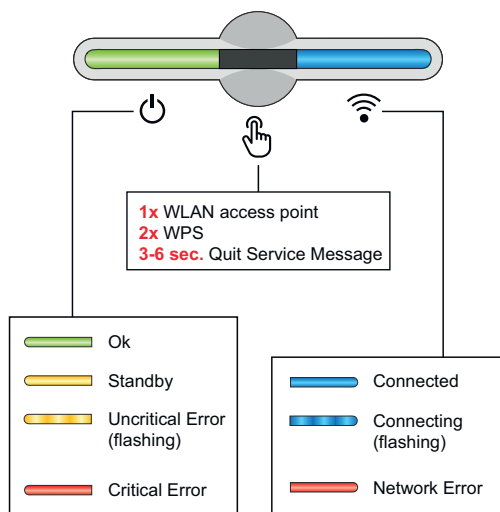

The status of the inverter is shown via the operating status LED. In the event of faults, carry out the individual steps in the Fronius Solar.web live app.

The optical sensor is actuated by touching with a finger.

The status of the connection is shown via the communication LED. To establish the connection, carry out the individual steps in the Fronius Solar.web live app.

## Sensor functions

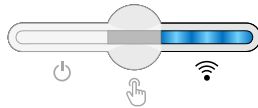

1x = WLAN access point (AP) is opened.

Flashing blue

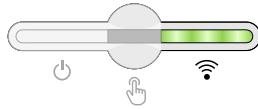

2x = WLAN Protected Setup (WPS) is activated.

Flashing green

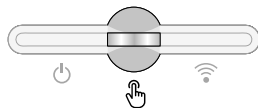

3 seconds (max. 6 seconds) = the service message is acknowledged.

Flashing white (rapidly)

## LED status indicator

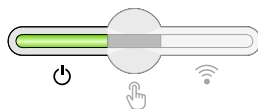

The inverter is operating correctly.

Lights up green

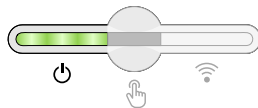

The inverter starts.

Flashing green

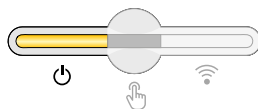

The inverter is in standby, is not operational (e.g. no feed-in at night) or is not configured.

Lights up yellow

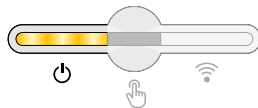

The inverter indicates a non-critical status.

Flashing yellow

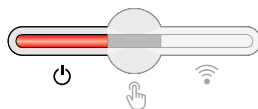

The inverter indicates a critical status and there is no grid power feed process.

Lights up red

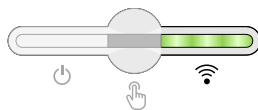

The network connection is being established via WPS.  
2x = WPS search mode.

Flashing green

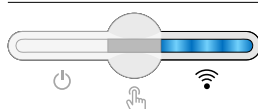

The network connection is being established via WLAN AP.

1x = WLAN AP search mode (active for 30 minutes).

Flashing blue

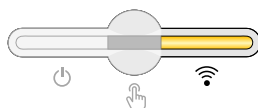

The network connection is not configured.

Lights up yellow

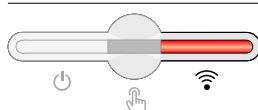

The inverter is operating correctly, a network fault is indicated.

Lights up red

## LED status indicator

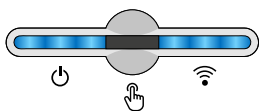

The inverter is performing an update.

⏻ / 📶 Flashing blue

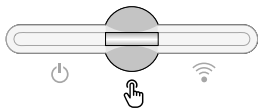

There is a service message.

👆 Lights up white



# **Installation and commissioning**



## **System component compatibility**

All installed components in the photovoltaic system must be compatible and have the necessary configuration options. The installed components must not restrict or negatively influence the functioning of the photovoltaic system.

### **NOTE!**

#### **Risk due to components in the photovoltaic system that are not compatible and/or have limited compatibility.**

Incompatible components may limit and/or negatively affect the operation and/or functioning of the photovoltaic system.

- ▶ Only install components recommended by the manufacturer in the photovoltaic system.
  - ▶ Before installation, check the compatibility of components not expressly recommended with the manufacturer.
-

# Installation location and position

## Choosing the location of the inverter

Please note the following criteria when choosing a location for the inverter:

Only install on a solid, non-flammable surface

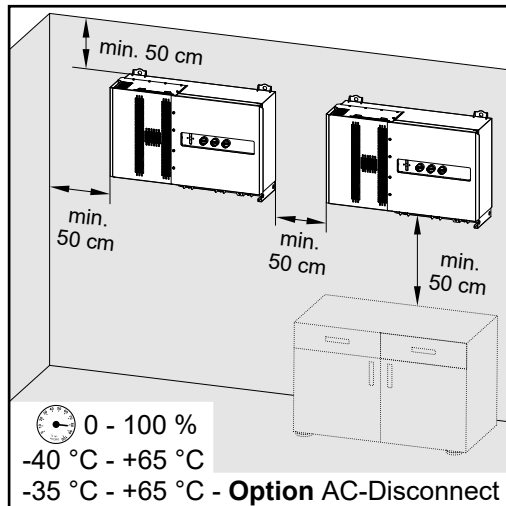

Max. ambient temperatures: -40 °C / +65 °C

\* with built-in AC disconnect option: -35 °C / +65 °C

Relative humidity: 0 - 100%

When installing the inverter in a switch cabinet or similar closed environment, it is necessary to make sure that the hot air that develops will be dissipated by forced-air ventilation.

When installing the inverter on the outer walls of cattle sheds, it is important to keep a minimum clearance of 2 m between all sides of the inverter and air vents and building openings.

The following surfaces are permissible for installation:

- Walls (corrugated metal walls [mounting rails], brick walls, concrete walls, or other non-flammable surfaces sufficiently capable of bearing loads)
- Poles (installed using mounting rails, behind the solar modules directly on the PV mounting system)
- Flat roofs (if this is for a film roof, make sure that the films comply with the fire protection requirements and are not highly flammable. Observe the national regulations.)
- Covered car park roofs (no overhead installation)

The DC disconnects must always be freely accessible after installation of the inverter.

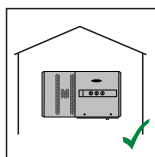

The inverter is suitable for indoor installation.

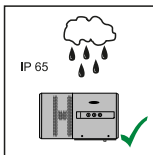

The inverter is suitable for outdoor installation.

Because of its IP 65 protection class, the inverter is resistant to water jets from any direction and can also be used in damp environments.

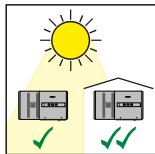

The inverter is suitable for outdoor installation.

To keep the heating of the inverter as low as possible, it is better not to expose the inverter to direct sunlight. Mount the inverter in a protected location, for example below the solar modules or under a roof overhang.

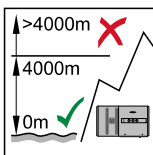

**IMPORTANT!** The inverter must not be installed or used at altitudes above 4000 m.

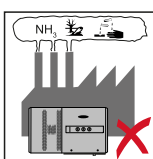

Do not install the inverter in:

- Areas where it may be exposed to ammonia, corrosive gases, acids or salts (e.g. fertiliser storage areas, vent openings for livestock stables, chemical plants, tanneries, etc.)

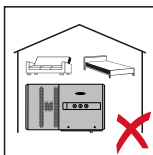

Due to the noise generated by the inverter under certain operating conditions, it should not be installed close to living areas.

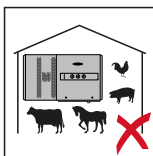

Do not install the inverter in:

- Areas where there is an increased risk of accidents from farm animals (horses, cattle, sheep, pigs, etc.)
- Stables or adjoining areas
- Storage areas for hay, straw, chaff, animal feed, fertilizers, etc.
- Storage or processing areas for fruit, vegetables or viticulture products
- Areas used in the preparation of grain, green fodder or animal feeds



The inverter is designed to be dust-tight (IP 65). However, in areas with high dust accumulation, the cooling surfaces may collect dust and this may impair the thermal performance. In such cases, regular cleaning is required. Consequently, we do not recommend installation in places and environments with strong dust formation.

**Installation position**

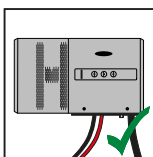

The inverter is designed to be installed vertically on a vertical wall. The optional floor racks must not be used for vertical mounting.

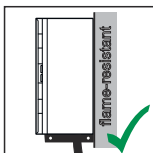

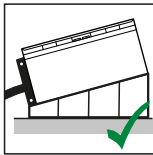

The inverter should have a minimum inclination of 3° in a horizontal installation position so that water can run off. Mounting of the optional floor racks is recommended. The floor racks may only be used on an installation position of 0 - 45°.

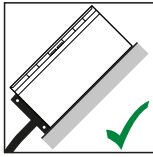

The inverter is suitable for installation on a sloping surface.

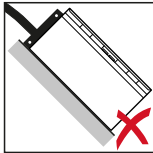

Do not install the inverter on a sloping surface with its connection sockets at the top.

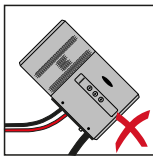

Do not install the inverter at an angle on a vertical wall or column.

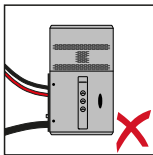

Do not install the inverter horizontally on a vertical wall or pillar.

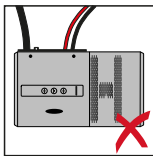

Do not install the inverter on a vertical wall or pillar with its connection sockets facing upwards.

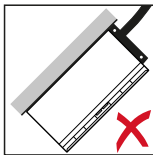
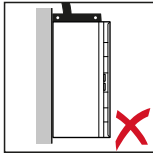

Do not install the inverter overhanging with the connection sockets at the top.

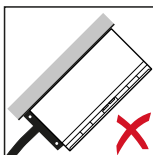

Do not install the inverter overhanging with the connection sockets at the bottom.

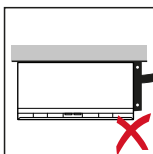

Do not install the inverter on the ceiling.

# Transport

## Crane transport

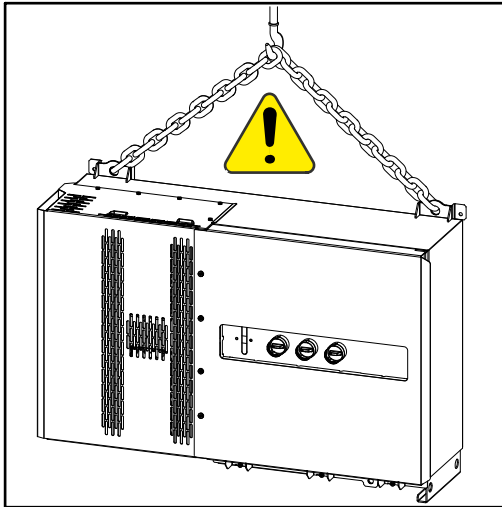

**⚠ WARNING!**

**Danger of serious injury and damage from articles being dropped or falling over.**

When transporting by crane:

- ▶ Hook chains and ropes onto the suspension points only
- ▶ Always hook chains and ropes onto both suspension points

## Transporting by counterbalanced lift truck or lift truck

**⚠ WARNING!**

**Equipment that falls or topples over can cause serious or even fatal injury.**

- ▶ Secure the inverter to prevent it from falling over when transporting on a counterbalanced lift truck or lift truck.
- ▶ Avoid sudden changes in direction, braking or acceleration

# Mounting the inverter

## Selecting the fixing material

Use the corresponding fixing materials depending on the subsurface and observe the screw dimension recommendations for the mounting bracket. The installer is responsible for selecting the correct type of fixing.

## Mounting bracket dimensions

Dimensions of the mounting bracket - all dimensions in mm.

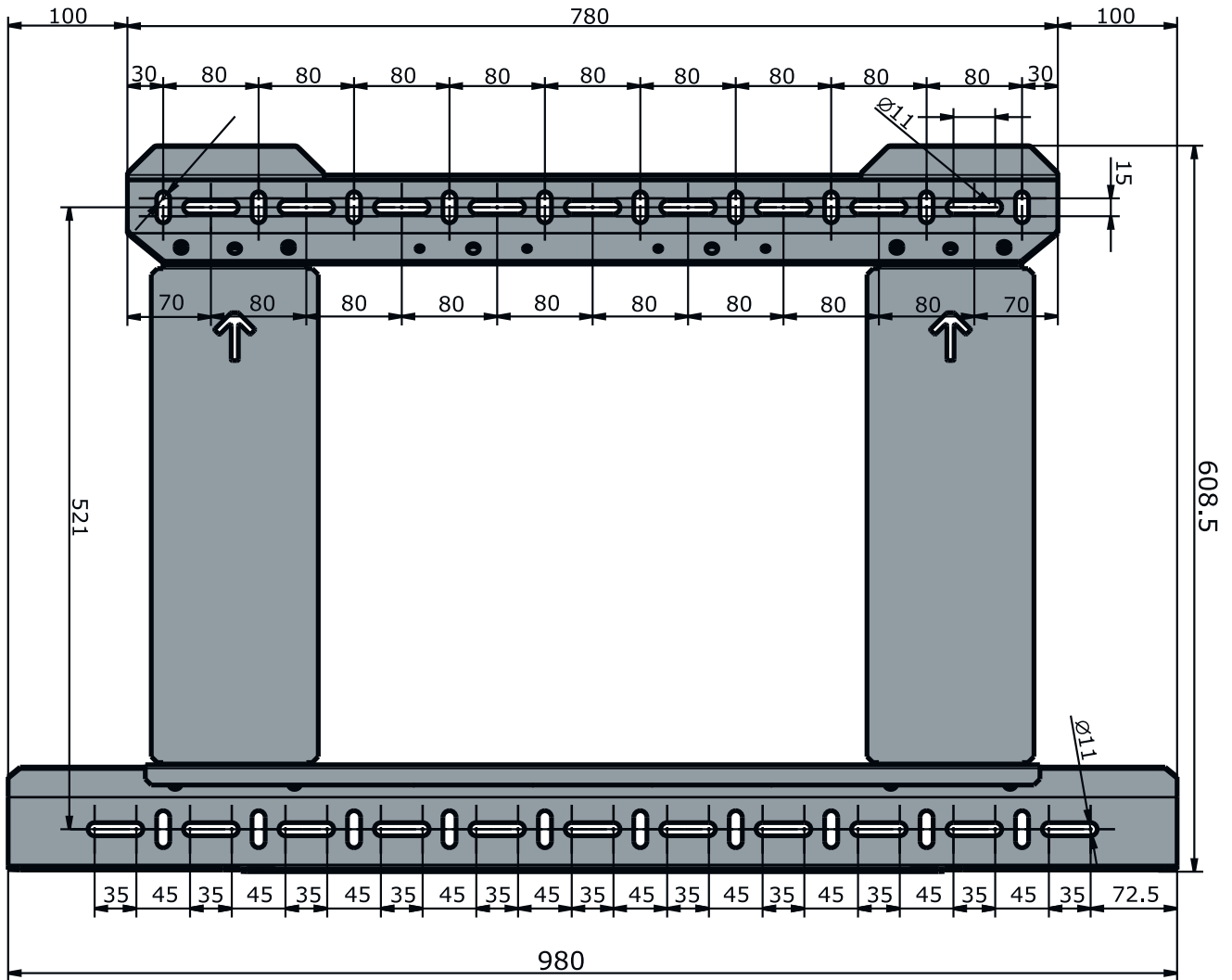

## Mounting the inverter on the wall

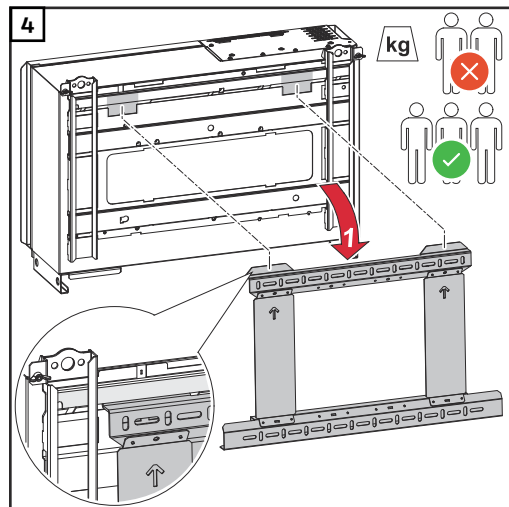
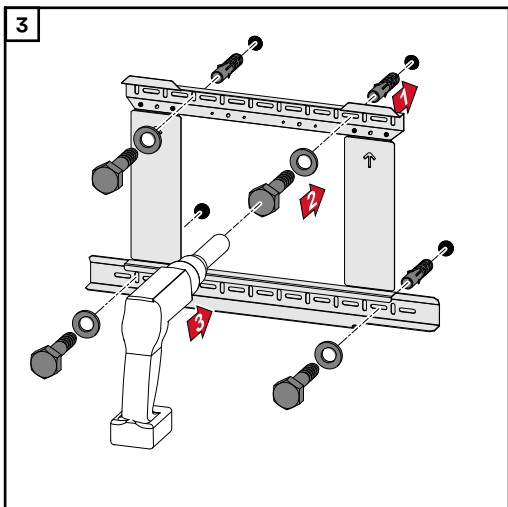
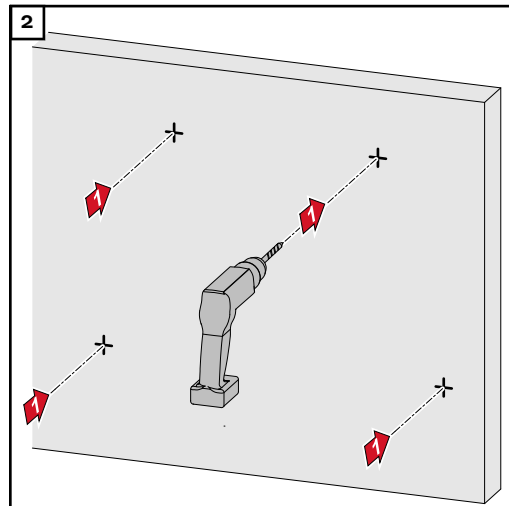
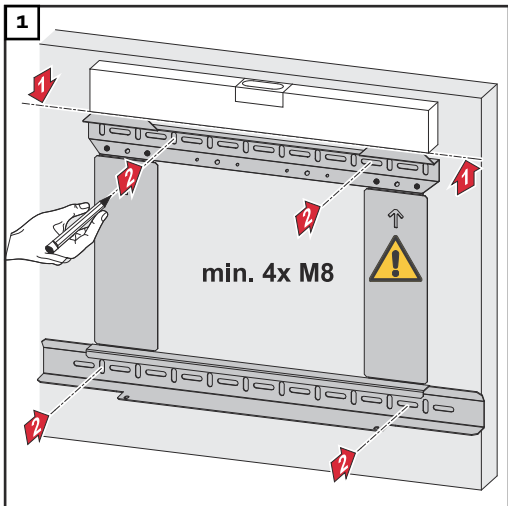

Observe the local regulations for lifting heavy loads or use a crane to lift the device (attach to crane-hoisting lugs)

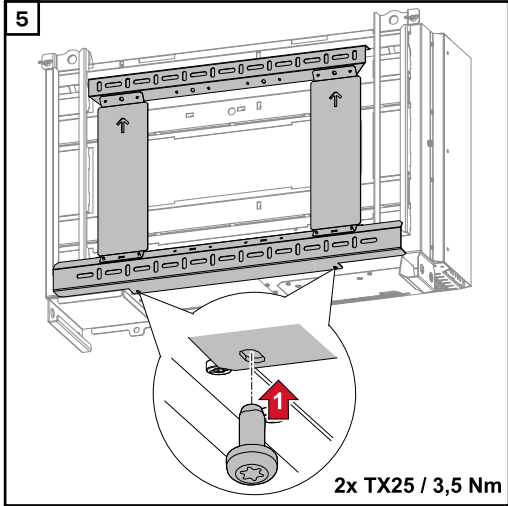

To attach the inverter to the mounting bracket, use only the screws included in the scope of delivery.

## Mounting the inverter on floor racks

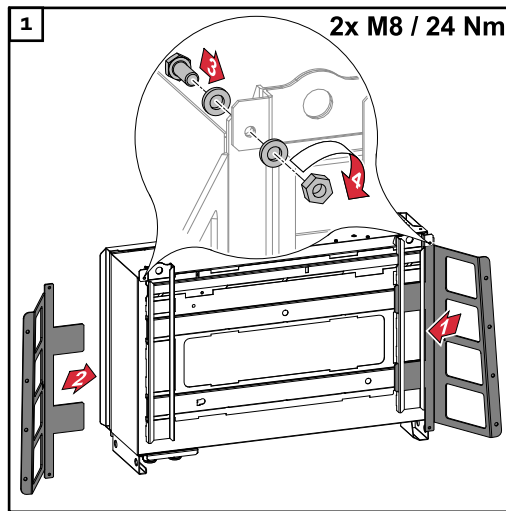

The floor racks can be ordered as an optional accessory.

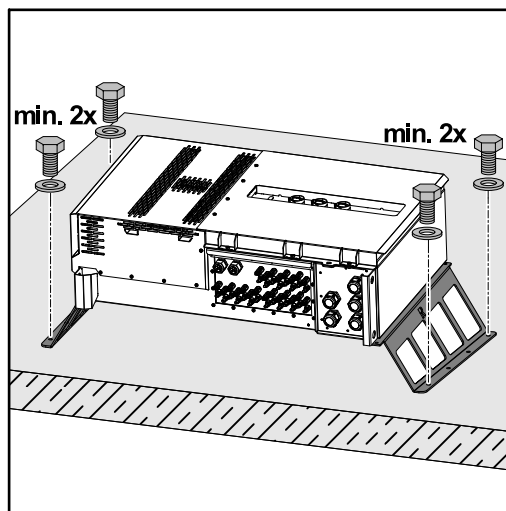

Mounting the inverter on a horizontal mounting surface is not mandatory, but recommended. Depending on the surface, different wall plugs and screws are required for floor mounting the floor racks. Wall plugs and screws are therefore not included in the scope of supply of the inverter. The installer is responsible for selecting the correct wall plugs and screws.

**2** Mount the inverter and floor racks securely to a suitable surface using the appropriate installation materials

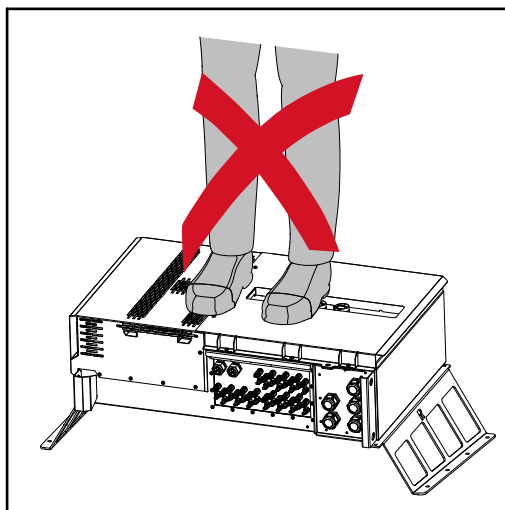

Do not climb onto the device!

# Connecting the inverter to the public grid (AC side)

## Monitoring the grid

**IMPORTANT!** To provide the best possible grid monitoring, the resistance in the leads to the mains connections should be as low as possible.

## AC connection area

**IMPORTANT!** Only the following cables may be connected to V-type terminals:

- RE (solid round conductor)
- RM (stranded round conductor)
- SE (solid sector conductor)
- SM (stranded sector conductor)
- Fine-core cables only in conjunction with ferrules

Fine-core cables without ferrules may only be connected to the M12 threaded bolts of the grid connections using a suitable M12 cable lug; torque = 32 Nm

### Cable gland "Multicore" version

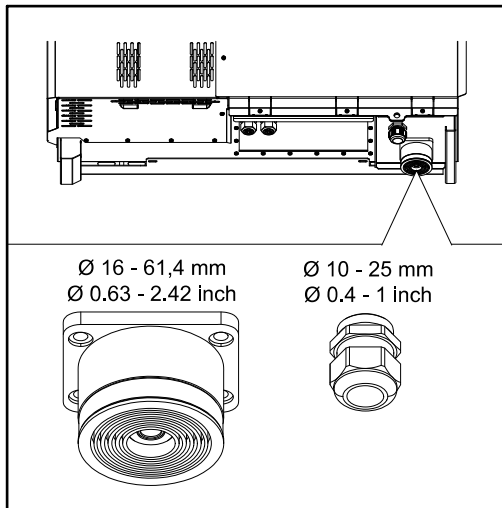

The following cable outer diameters are compatible with the larger bushing: 16 - 27.8 - 36.2 - 44.6 - 53 - 61.4 mm

For the small bushing (M32 PG gland), earth cables of 10 - 25 mm can be fed through.

### Cable gland "Singlecore" version

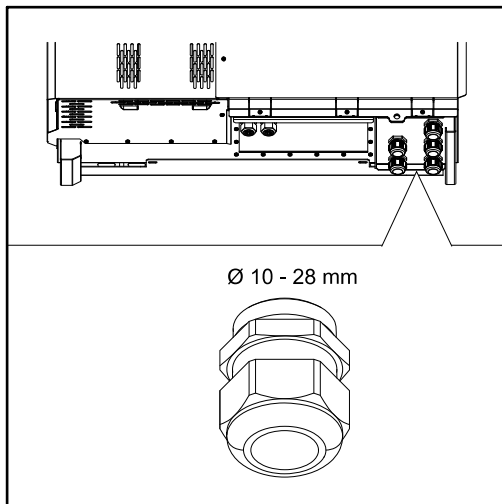

5 M40 bushings

### Cable gland "AC Daisy Chain" version

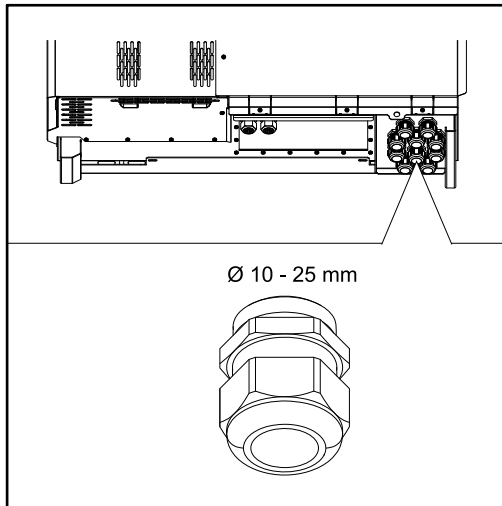

10 M32 bushings

### Connecting aluminium cables

Aluminium cables can be connected to the grid connections.

#### NOTE!

#### When connecting aluminium cables:

- ▶ Observe national and international guidelines regarding the connection of aluminium cables
- ▶ To protect the aluminium strands from oxidation, grease them with a suitable grease.
- ▶ Follow the instructions of the cable manufacturer

### Permitted cables

The temperature resistance of the AC cables must be at least 90 C.

If cables are used that do not meet this temperature requirement, pass the protective hose (item number: 4,251,050) over the phases (L1 / L2 / L3) and neutral conductor (N). The earthing PE does not have to be protected with a protective hose.

With the AC Daisy Chain option, all phases and neutral conductors must be protected with the protective hose. Two sets of protective hoses are therefore required for the AC Daisy Chain option.

#### Grid connections

Select sufficiently high cable cross sections depending on the power category and connection option!

Power category	Connection option	Cable cross section
Tauro 50-3 Tauro Eco 50-3	Singlecore/Multicore	35–240 mm <sup>2</sup> *
	Optional AC disconnector	35–240 mm <sup>2</sup> *
	Daisy Chain (without AC disconnector)	35–240 mm <sup>2</sup> *

<b>Grid connections</b>		
Select sufficiently high cable cross sections depending on the power category and connection option!		
<b>Power category</b>	<b>Connection option</b>	<b>Cable cross section</b>
Tauro Eco 99-3 Tauro Eco 100-3	Singlecore/Multicore	70–240 mm <sup>2</sup> *
	Optional AC disconnecter	70–240 mm <sup>2</sup> *
	Daisy Chain (without AC disconnecter)	70–240 mm <sup>2</sup> *

\* The cable cross-section of the neutral conductor can be reduced to 25 mm<sup>2</sup> if no local directives or standards require otherwise.

### Maximum alternating current fuse protection

#### NOTE!

**There is no general requirement to use a residual current device.**

If a residual current device (RCD) is nevertheless used, a type B with a tripping current of at least 1000 mA must be used.

#### NOTE!

**The inverter can be used with an automatic circuit breaker of a maximum of 355 A.**

	Tauro 50-3-D / 50-3-P	Tauro Eco 50-3-D / 50-3-P	Tauro Eco 99-3-P	Tauro Eco 99-3-D	Tauro Eco 100-3-P	Tauro Eco 100-3-D
Recommended output overcurrent protection [A] for 50 kW output power	80	80	-	-	-	-
Recommended output overcurrent protection [A] for 100 kW output power (example: Daisy Chaining)	160	160	160	160	160	160
Recommended output overcurrent protection [A] for 150 kW output power (example: Daisy Chaining)	250	250	250	250	250	250
Recommended output overcurrent protection [A] for 200 kW output power (example: Daisy Chaining)	355	355	355	355	355	355

### Changing the clamping area for V-type terminal

The clamping range of the V-type terminal is 35 - 150 mm<sup>2</sup> when delivered. The clamping range can be changed to 185 - 240 mm<sup>2</sup> by a simple modification of the V-type terminal.

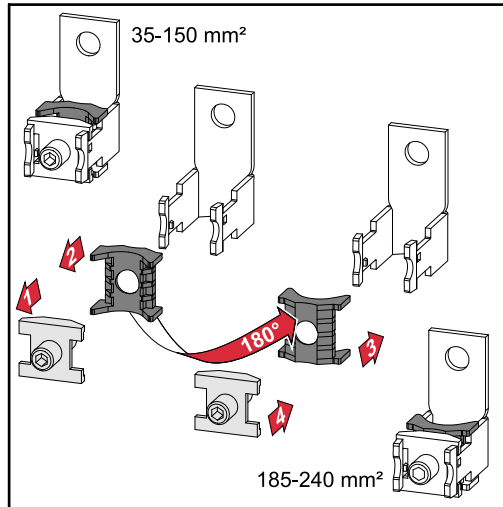

### Sector conductors at the V-type terminal

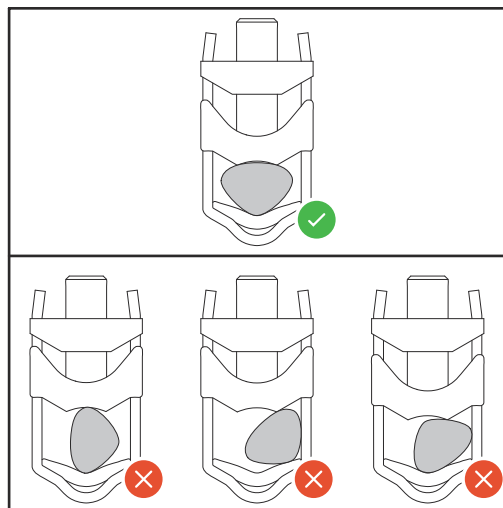

### Additional PE introduction for earthing

An optional hole can be made on the right side of the housing at the bottom for an additional PE introduction.

#### CAUTION!

#### **Danger from faulty or incorrect holes.**

This may lead to injuries to the eyes and hands as a result of flying debris and sharp edges, as well as damage to the inverter.

- ▶ When drilling, wear suitable protective goggles.
- ▶ Only use a step drill when drilling.
- ▶ Ensure that nothing is damaged inside the device (for example connection block).
- ▶ Adapt the diameter of the hole to match the corresponding connection.
- ▶ Deburr the holes using a suitable tool.
- ▶ Remove the drilling residues from the inverter.

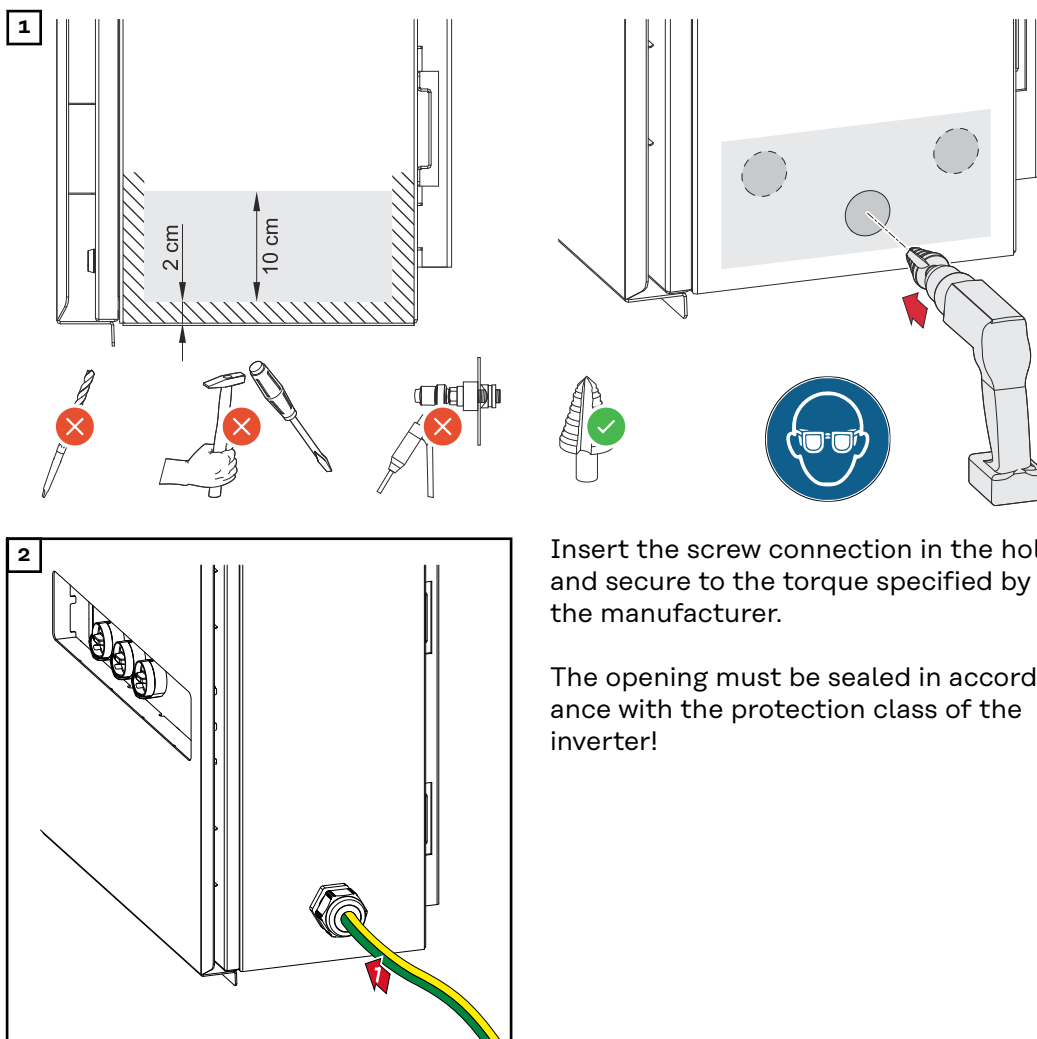

Insert the screw connection in the hole and secure to the torque specified by the manufacturer.

The opening must be sealed in accordance with the protection class of the inverter!

## Safety

### **WARNING!**

#### **Danger due to grid voltage and DC voltage from solar modules.**

An electric shock can be fatal.

- ▶ Ensure that both the AC side and the DC side of the inverter are de-energised before carrying out any connection work.
- ▶ Only an authorised electrical engineer is permitted to connect this equipment to the public grid.

### **CAUTION!**

#### **Risk of damage to the inverter as the result of incorrectly tightened cable connections.**

Incorrectly tightened cable connections can cause heat damage to the inverter that may result in a fire.

- ▶ When connecting AC and DC cables, ensure that all the cables are tightened to the inverter terminals with the specified torque.

**IMPORTANT!** For PE connection, the requirements defined under "Safety rules" for a safe connection of the PE conductor must also be observed.

**Opening the in-  
verter**

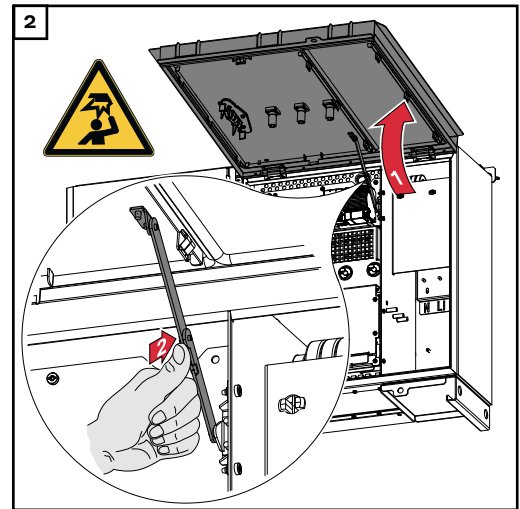
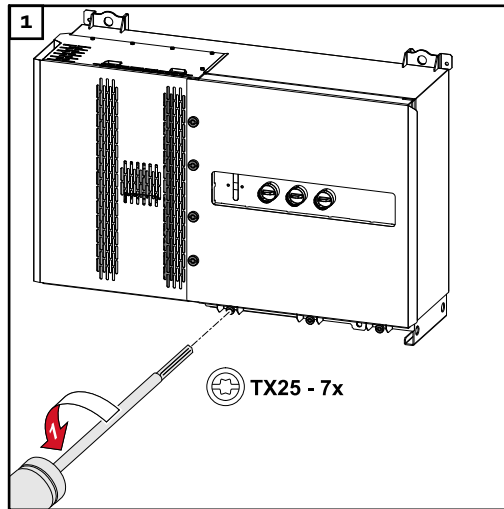

**Switching off the  
AC disconnector  
option**

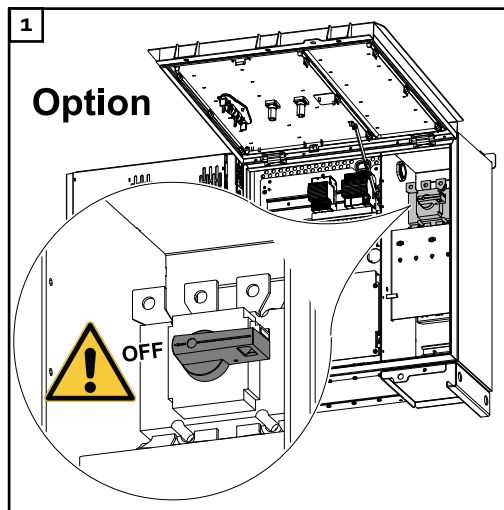

**Connecting the  
inverter to the  
public grid -  
Singlecore**

Ensure that the phases are connected in the right order: PE, N, L1, L2 and L3.

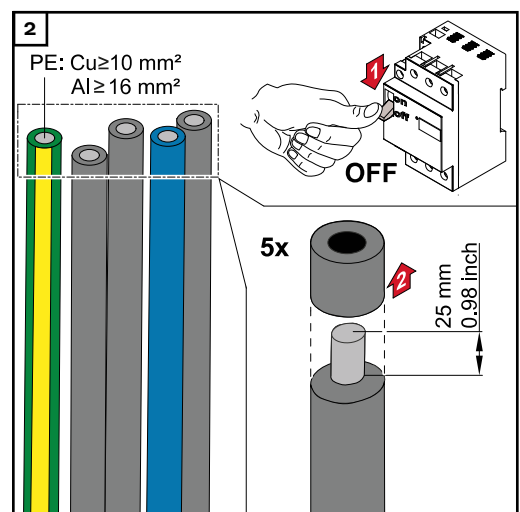
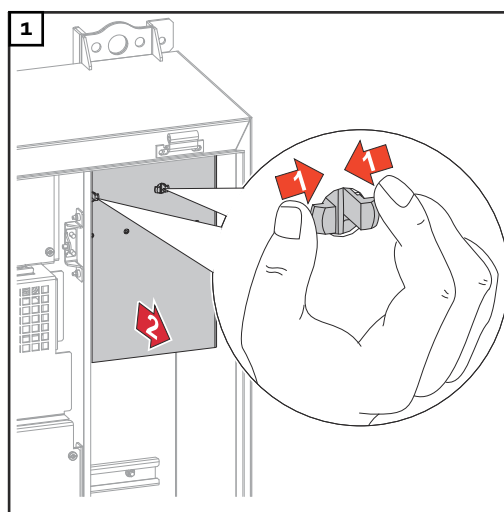

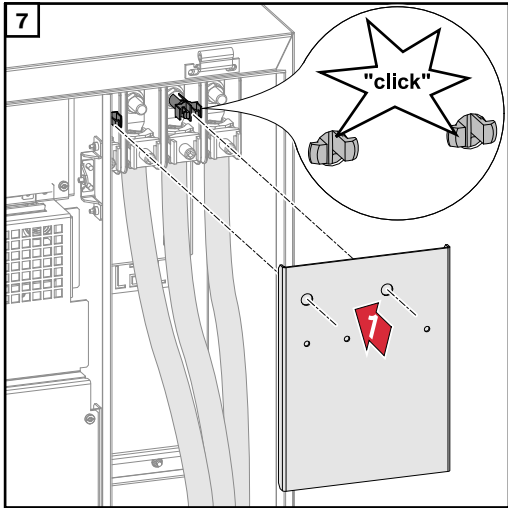
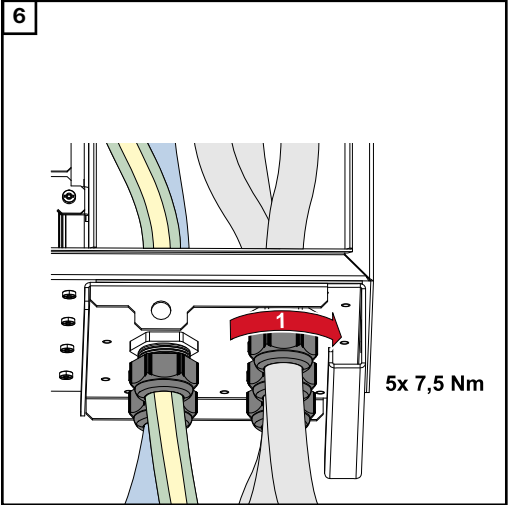
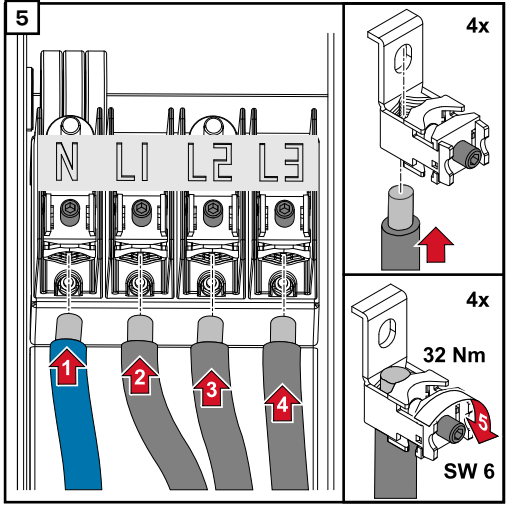
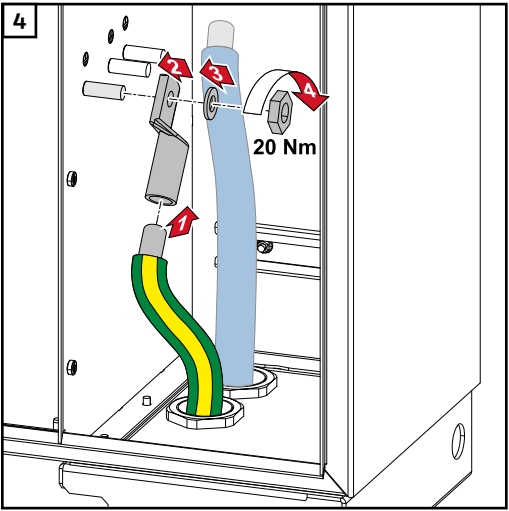
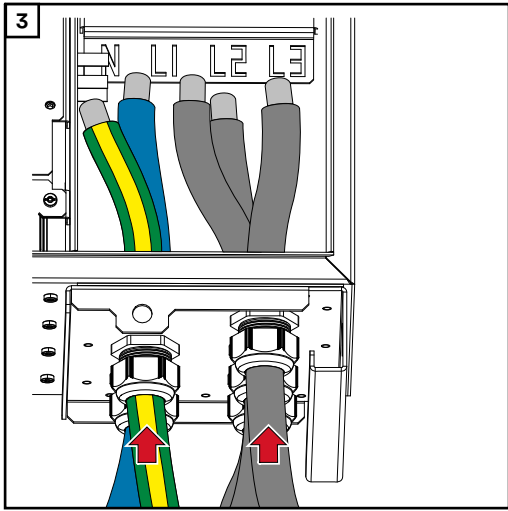

**Connecting the inverter to the public grid - Singlecore with PEN conductor**

Ensure that the phases are connected in the right order: PE, PEN, L1, L2 and L3.

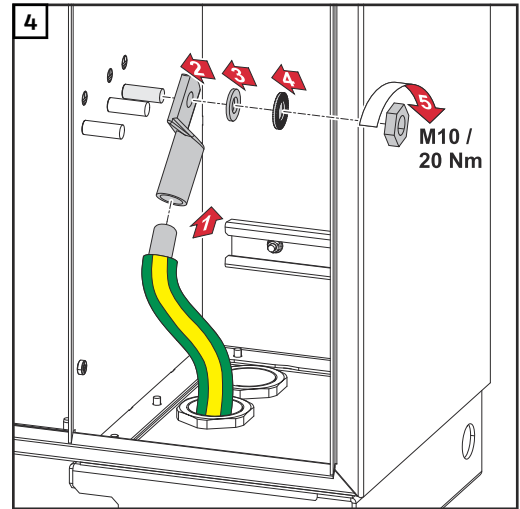
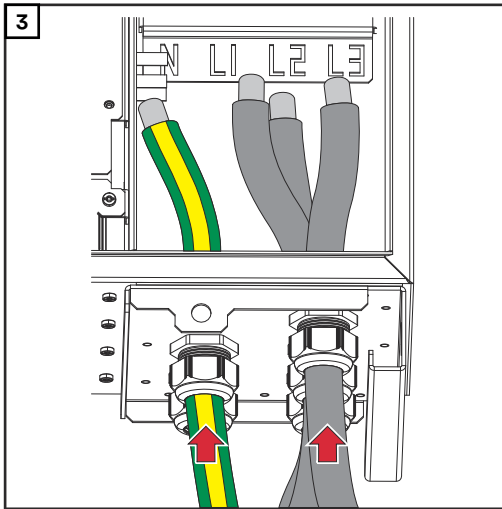
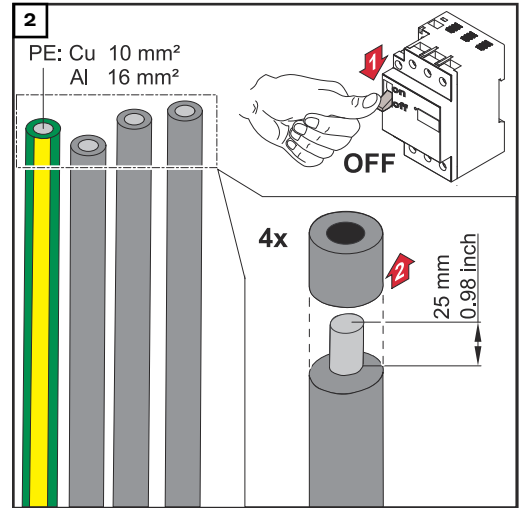
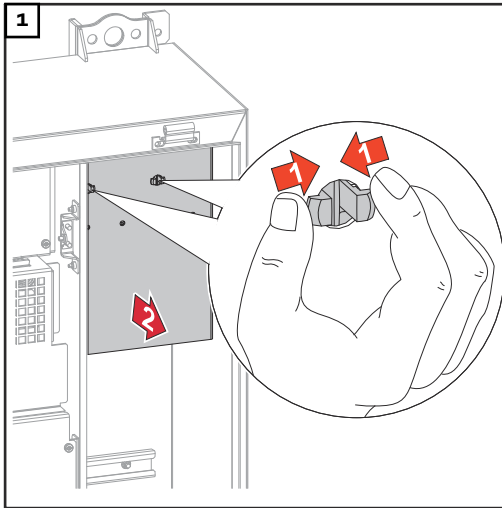

**NOTE!**  
The PEN conductor must be produced with ends that are permanently marked blue, according to the national provisions.

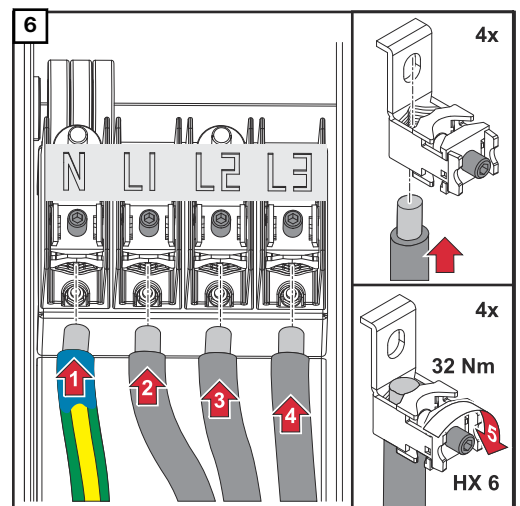
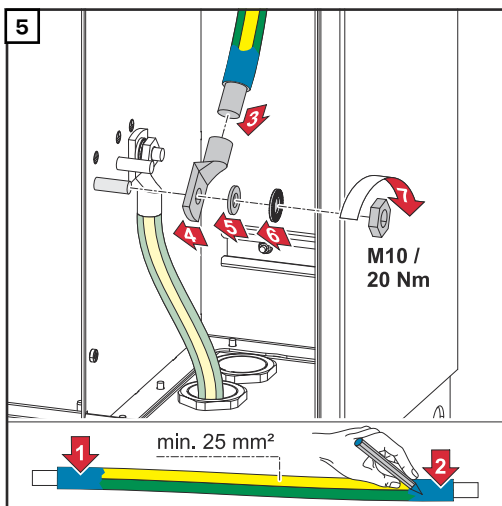

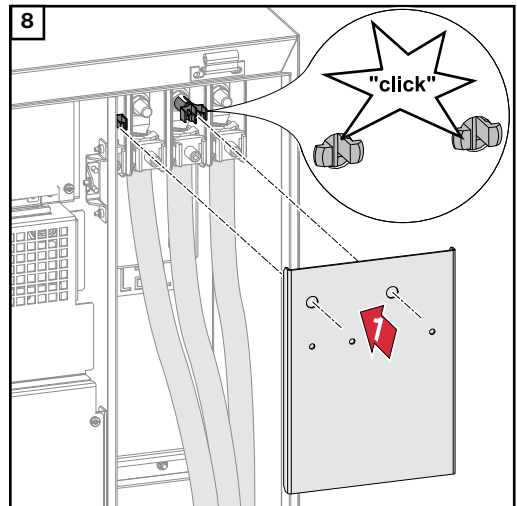
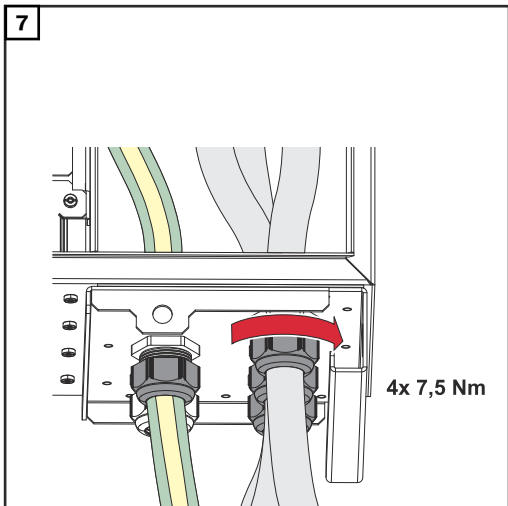

**Connecting the inverter to the public grid - Multicore**

When connecting, ensure that the phases are in the correct order: PE, N, L1, L2 and L3.

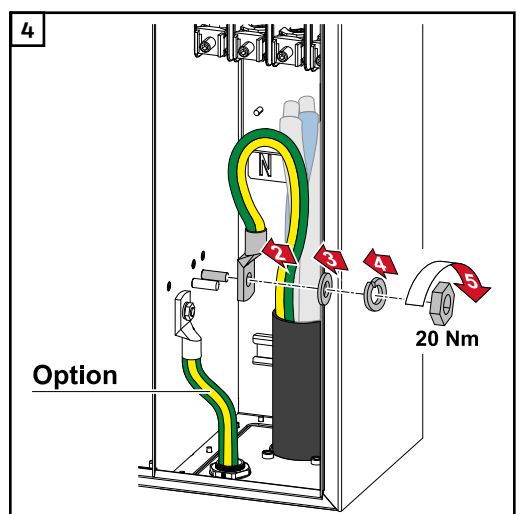
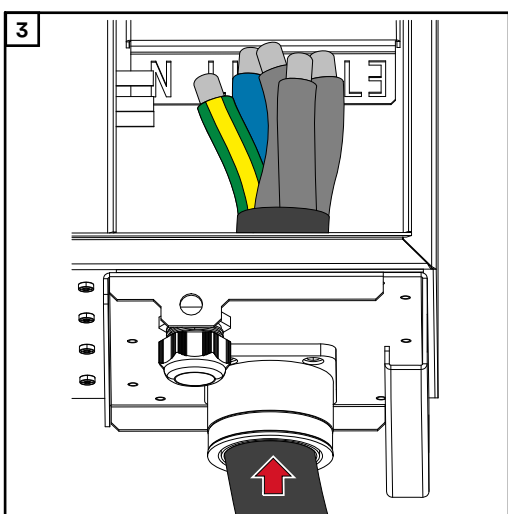
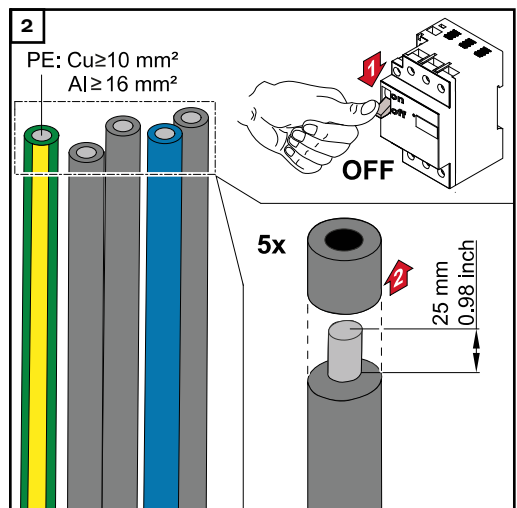
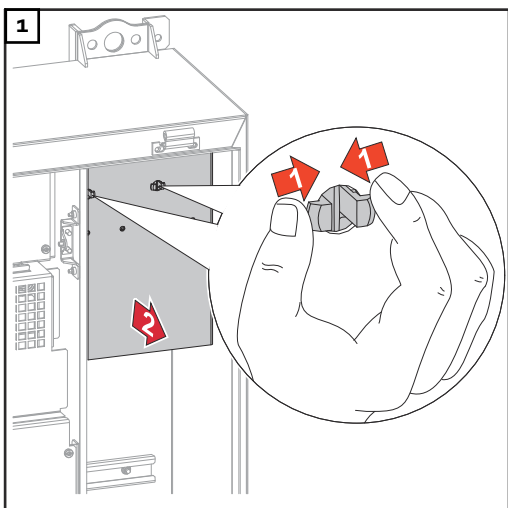

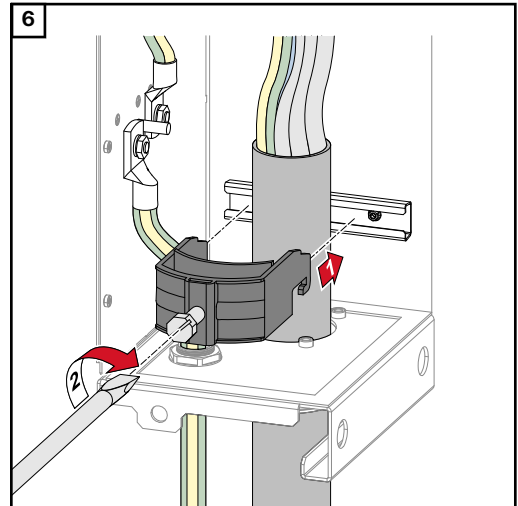
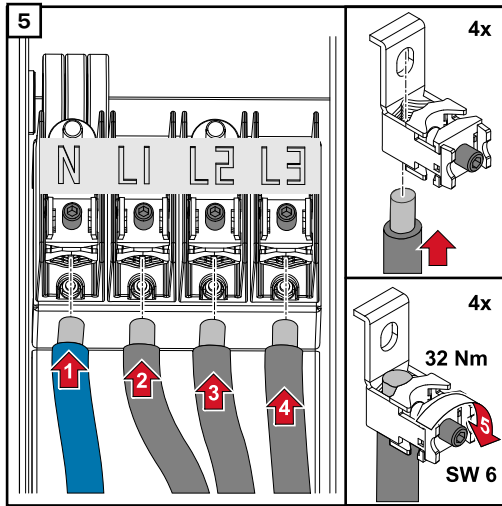

Secure to the torque specified by the manufacturer of the strain-relief device. The strain-relief device is not part of the scope of supply.

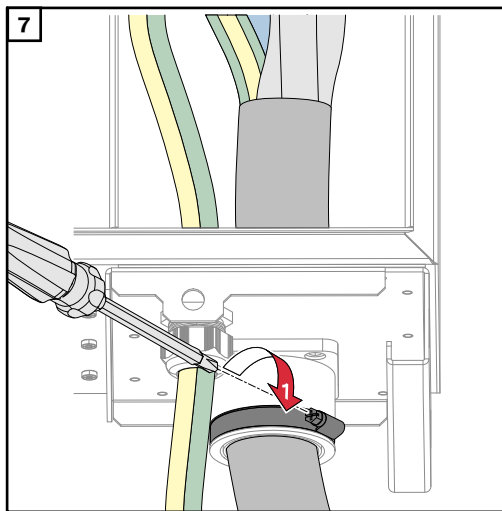

Secure to the torque specified by the manufacturer

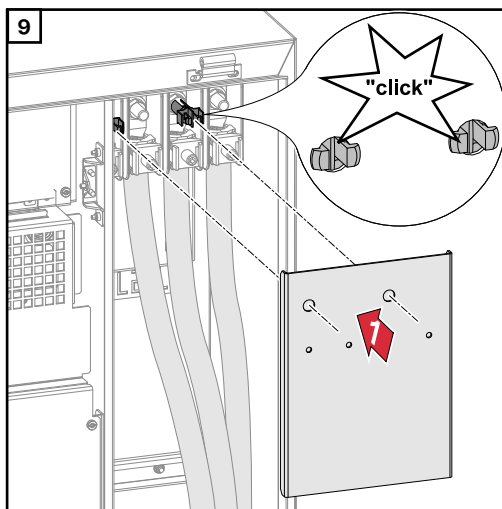
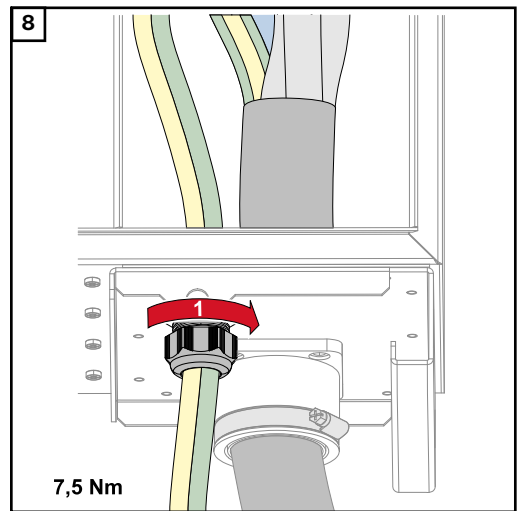

### Connecting the inverter to the public grid - Daisy Chain

Ensure that the phases are connected in the right order: PE, N, L1, L2 and L3.

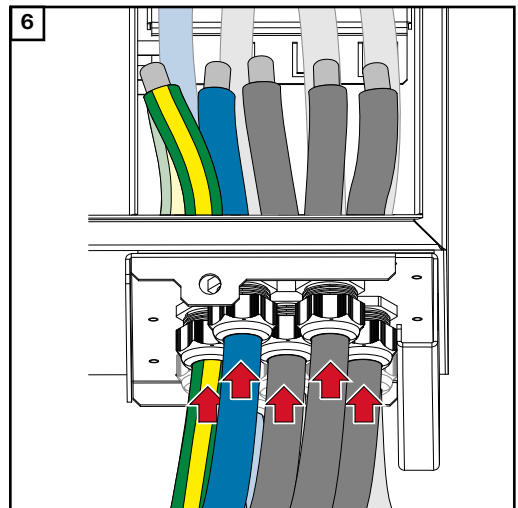
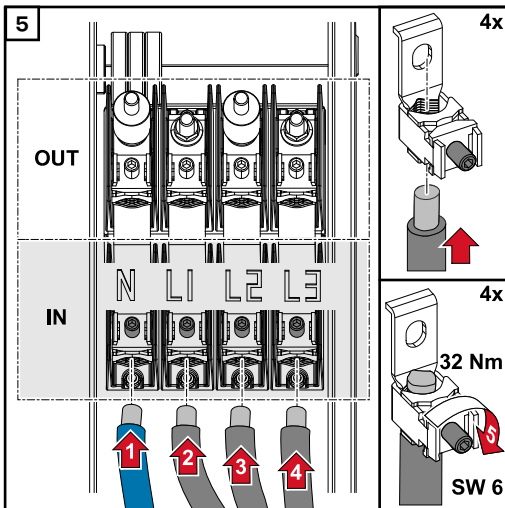
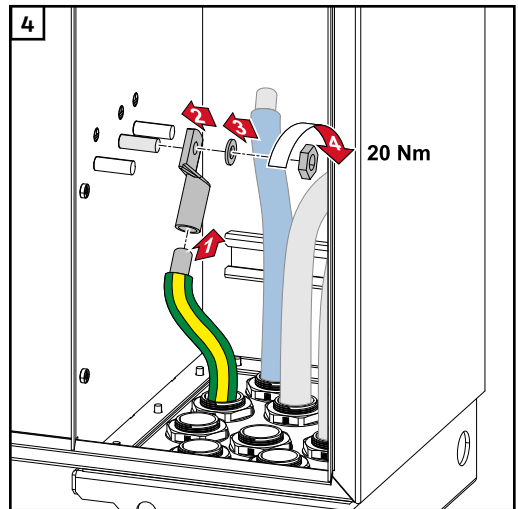
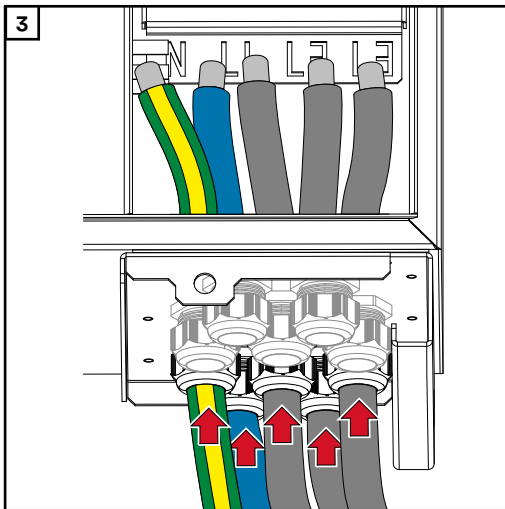
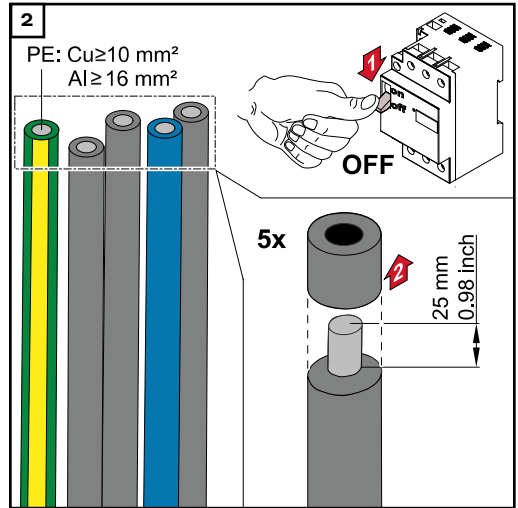
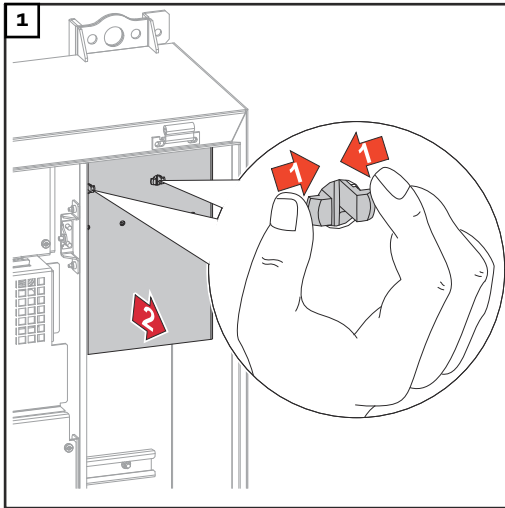

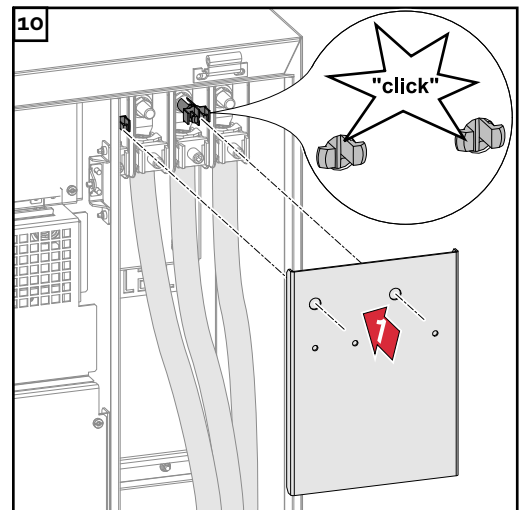
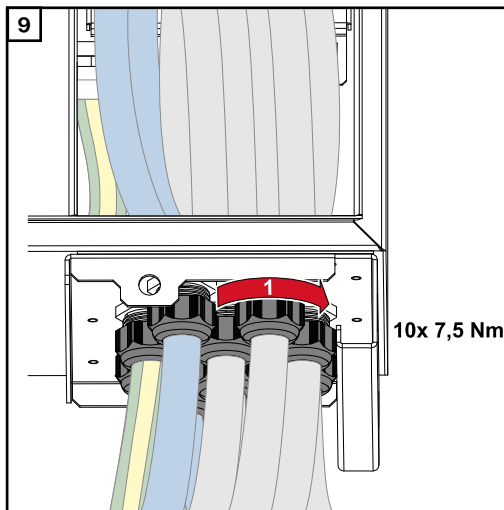
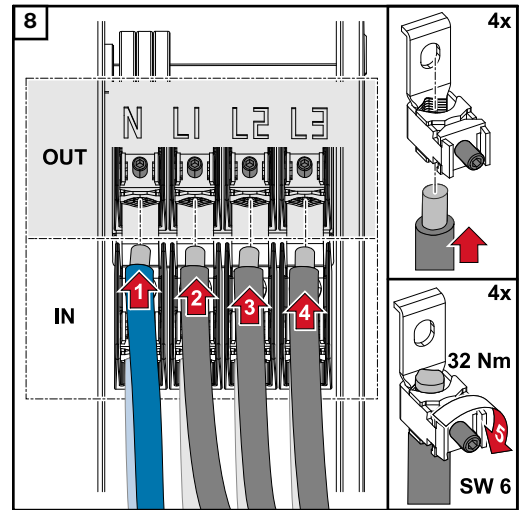
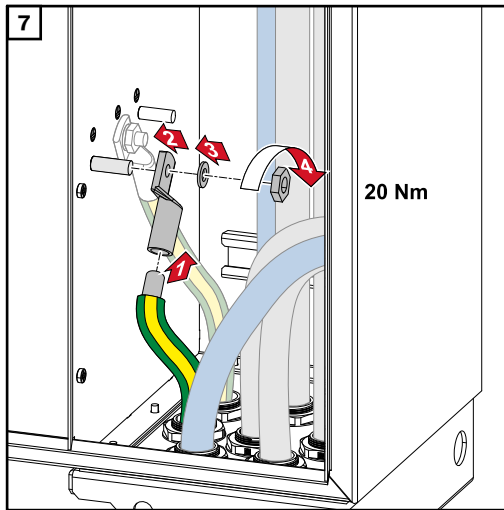

### Connecting cables with a cable lug

Alternatively, a cable with a cable lug can be connected to the M12 threaded bolts on the grid connections in order to connect the cables to the V-type terminals.

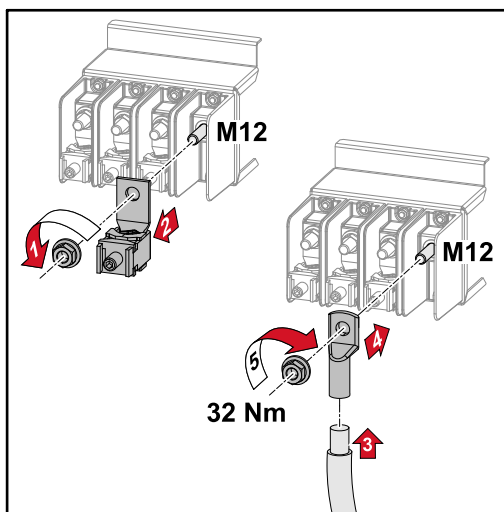

# Connecting the PV cable to the inverter

## Safety

### **WARNING!**

**Danger due to grid voltage and DC voltage from solar modules that are exposed to light.**

An electric shock can be fatal.

- ▶ Prior to any connection work, disconnect the inverter on the AC side and the DC side.
- ▶ Only an authorised electrical technician is permitted to connect this equipment to the public grid.

### **WARNING!**

**Danger of electric shock due to incorrectly connected terminals / PV plug connectors.**

An electric shock can be fatal.

- ▶ When connecting version D ("direct string"), ensure that every pole of a string is fed across the same PV input, e.g.:  
'+ pole string 1' at input PV 1.1+ and '- pole string 1' at input PV 1.1-

### **WARNING!**

**Danger from DC voltage. Even when the DC disconnectors are switched off, the fuse boards (100-3-D / 99-3-D) / fuse board (50-3-D) and everything before the DC disconnectors are live.**

An electric shock can be fatal.

- ▶ Prior to any connection work, disconnect the inverter on the AC side and the DC side.

### **CAUTION!**

**Risk of damage to the inverter as the result of incorrectly tightened terminals.**

Incorrectly tightened terminals can cause heat damage to the inverter that may result in a fire.

- ▶ When connecting AC and DC cables, ensure that all the terminals are tightened to the specified torque.

### **CAUTION!**

**Risk of damage to the inverter due to PV modules that are not connected with the correct polarity.**

PV modules that are not connected with the correct polarity can cause thermal damage to the inverter.

- ▶ Measure the DC cables from the PV modules and connect them to the inverter with the correct polarity.

**⚠ CAUTION!**

**Risk of damage to the inverter by exceeding the maximum input current per string.**

Exceeding the maximum input current per string can cause damage to the inverter.

- ▶ Observe the maximum input current per string for the inverter according to the technical data.
- ▶ The maximum input current must not be exceeded even when using Y or T connectors.

**General comments regarding PV modules**

To enable suitable PV modules to be chosen and to use the inverter as efficiently as possible, it is important to bear the following points in mind:

- If insolation is constant and the temperature is falling, the open-circuit voltage of the PV modules will increase. The open-circuit voltage must not exceed the maximum permissible system voltage. If the open-circuit voltage exceeds the specified values, the inverter will be destroyed and all warranty claims will be forfeited.
- The temperature coefficients on the data sheet of the PV modules must be observed.
- Exact values for sizing the PV modules can be obtained using suitable calculation tools, such as the [Fronius Solar.creator](#).

**IMPORTANT!**

Before connecting up the PV modules, check that the voltage for the PV modules specified by the manufacturer corresponds to the actual measured voltage.



**IMPORTANT!**

The PV modules connected to the inverter must comply with the IEC 61730 Class A standard.

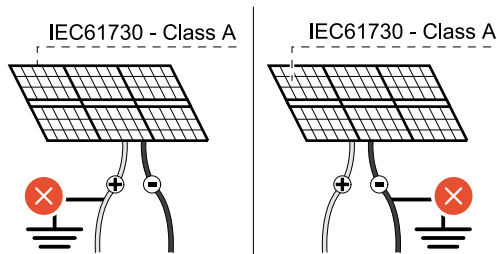

**IMPORTANT!**

Solar module strings must not be earthed.

max. 1000 V<sub>DC</sub>

**Permitted cables** The temperature resistance of the DC cables must be at least 90 °C.

### DC connections

Select sufficiently high cable cross sections depending on the device type!

Power category	Device type	Cable cross section
Tauro 50-3 / Eco 50-3 / Eco 99-3 / Eco 100-3	pre-combined	25 - 95 mm <sup>2</sup>
	direct	2,5 - 10 mm <sup>2</sup> (see data sheet for con- nector)

### DC fuse protec- tion - pre-com- bined



### CAUTION!

#### Risk of damage to the inverter as the result of incorrectly fused PV lines.

PV lines for the "pre-combined" model that are not fused can cause damage to the inverter.

- ▶ PV lines must be fused in a combiner box before the inverter ("pre-combined" version).

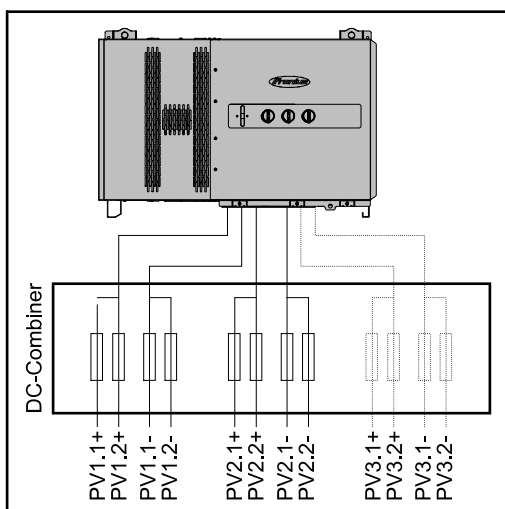

**Example of  
Fronius Tauro  
Eco 50-3-P /  
99-3-P / 100-3-P  
combiner box**

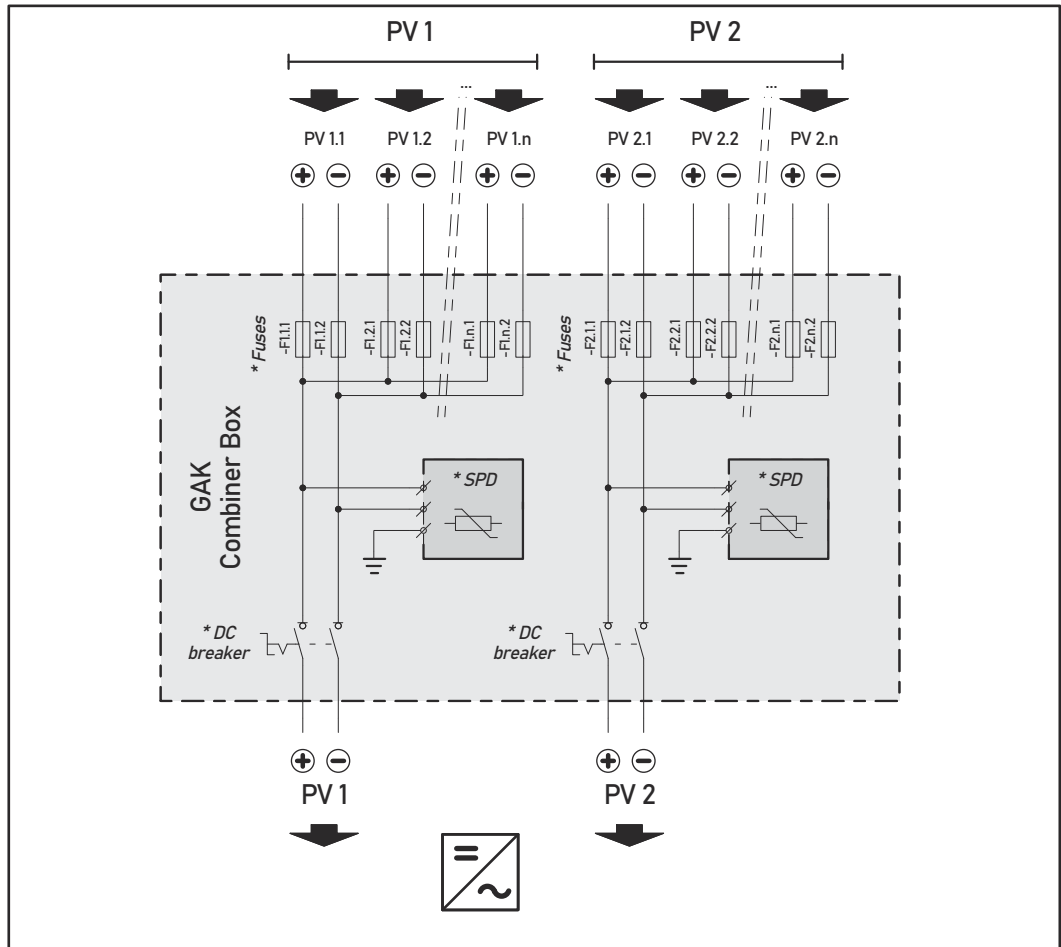

\* DC fuse optional depending on national standard / DC breaker optional / DC SPD optional

**Example Fronius Tauro 50-3-P combiner box**

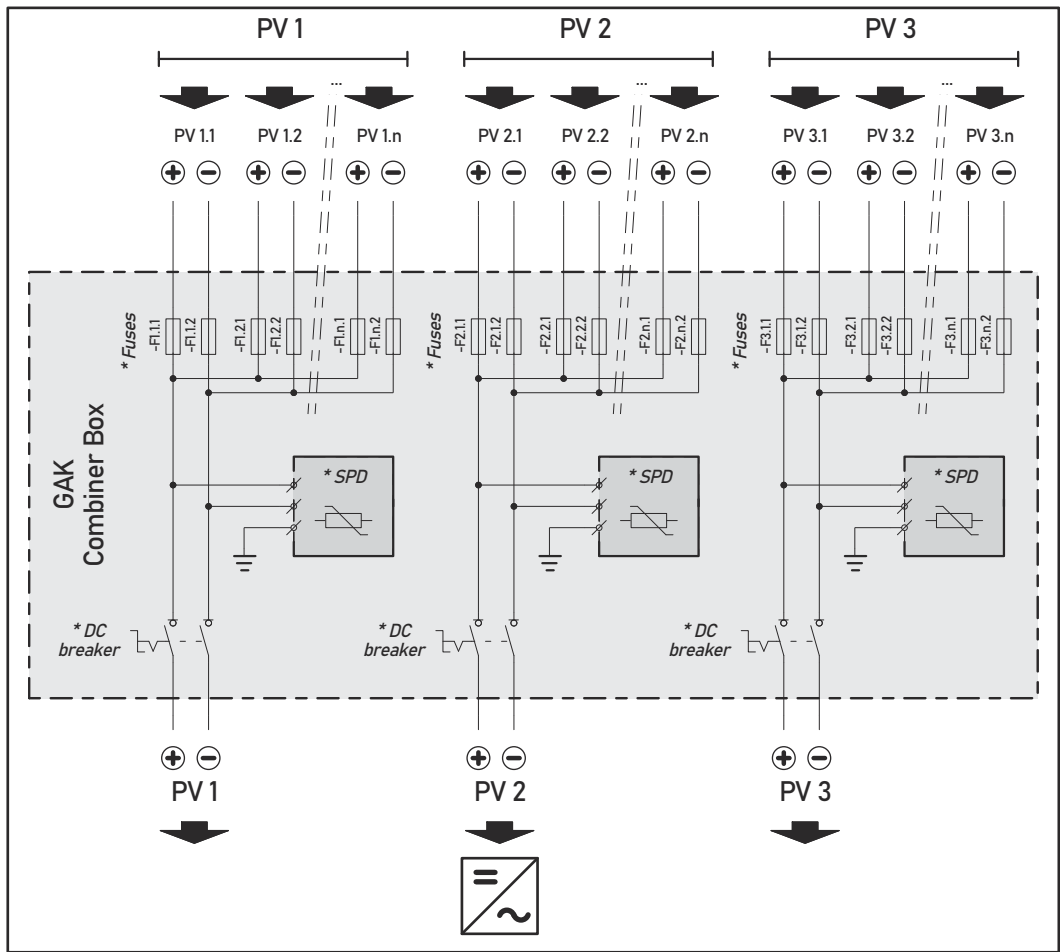

\* DC fuse optional depending on national standard / DC breaker optional / DC SPD optional

**Distribution of the solar module strings for the direct version**

Divide the existing solar module strings evenly between the PV inputs (PV1 / PV2 / PV3) of the inverter. Start with the odd inputs first and only then fill up the even inputs to divide the power as evenly as possible and extend the service life of the fuses, e.g.: (1.1, 2.1, 3.1, 1.3, 2.3...)

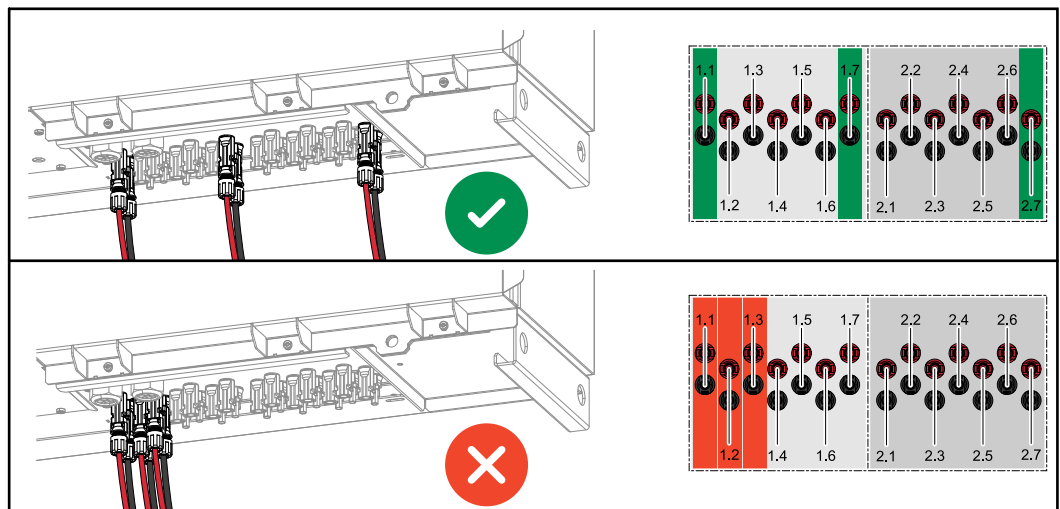

**Connecting PV cables - MC4 connector**

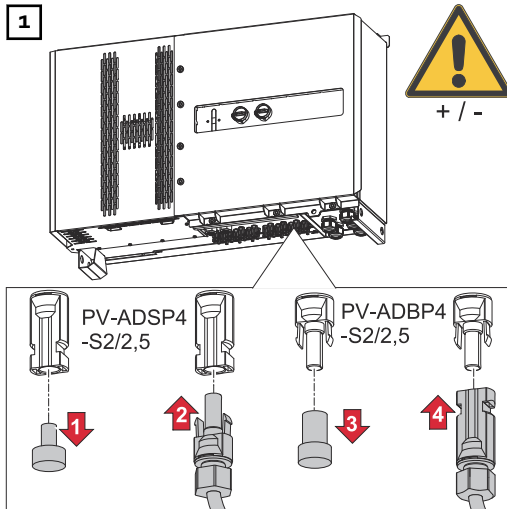

Connect the PV cables from the solar modules to the MC4 connectors as labelled

Unused MC4 connectors on the inverter must be covered with the cover plates supplied with the inverter.

**MC4 connector cover**

To protect the MC4 connectors, a cover plate can be mounted on the inverter. The cover plate can be ordered as an optional accessory together with the floor racks.

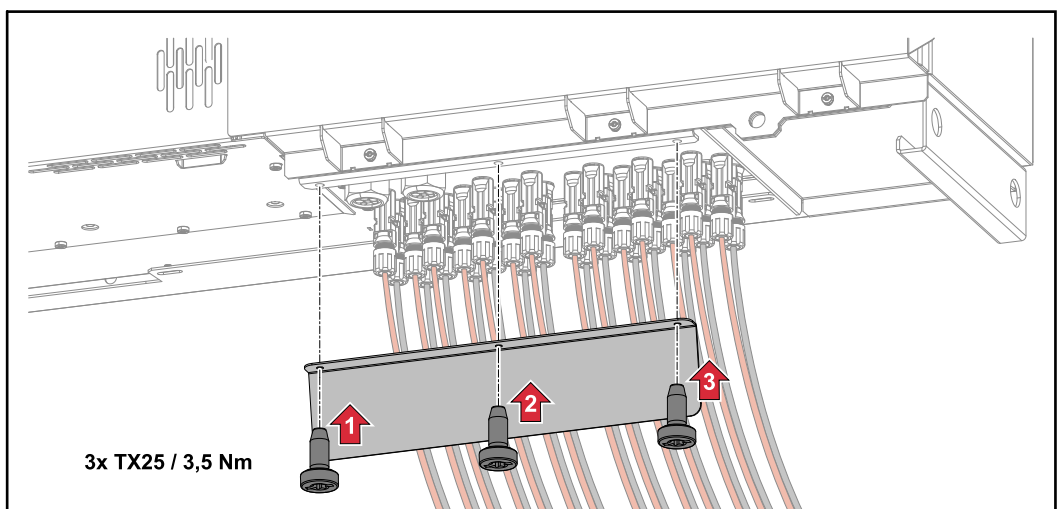
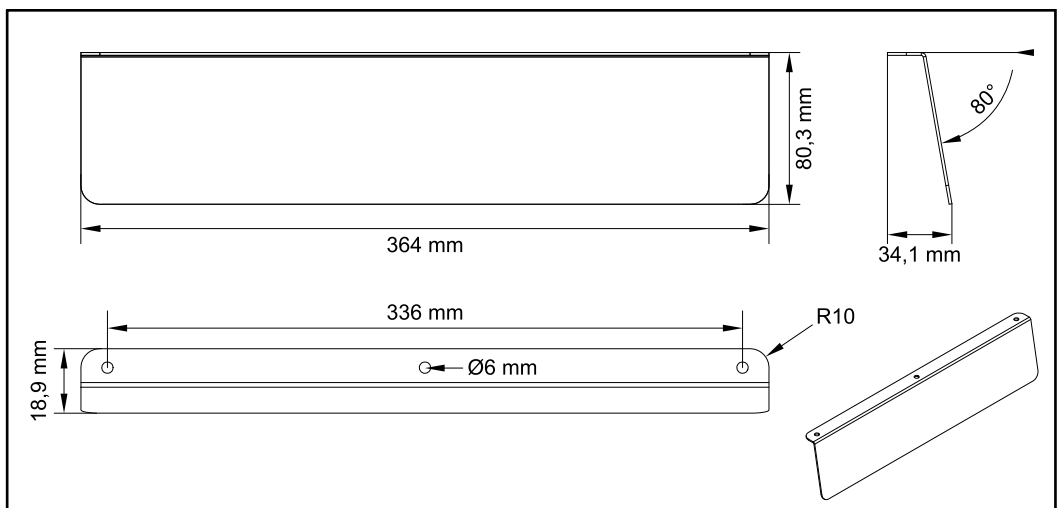

### Connecting PV cables - Pre-combined

Solar module strings that are combined in a DC combiner box, must, according to the applicable national regulations, be fused per string in the DC combiner box!

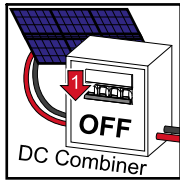

Before working in the connection area of the inverter, the DC voltage must be switched off. This can also be done in the DC combiner box.

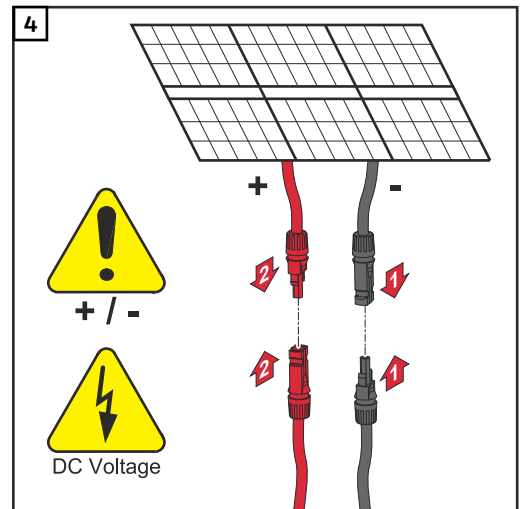
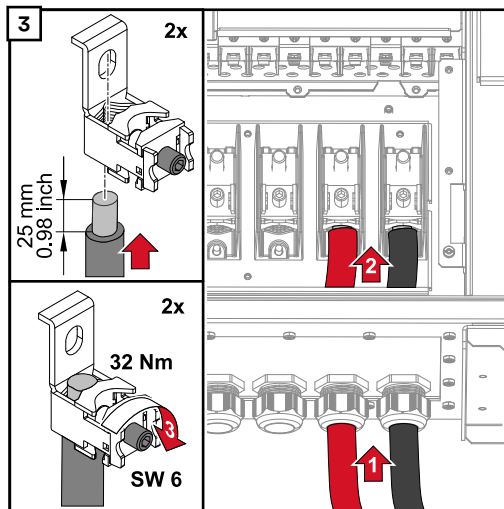
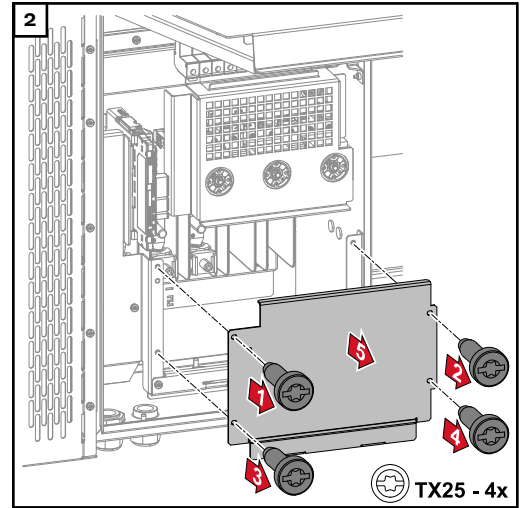
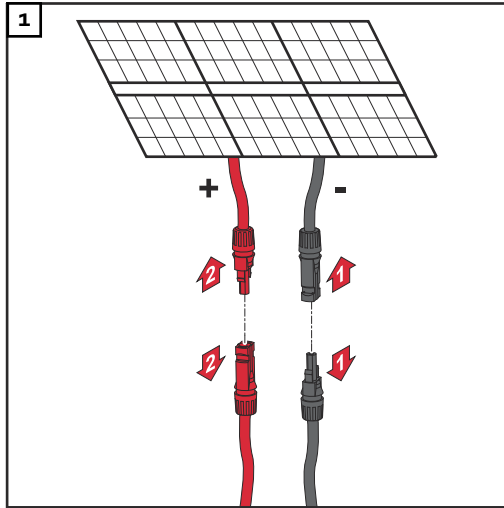

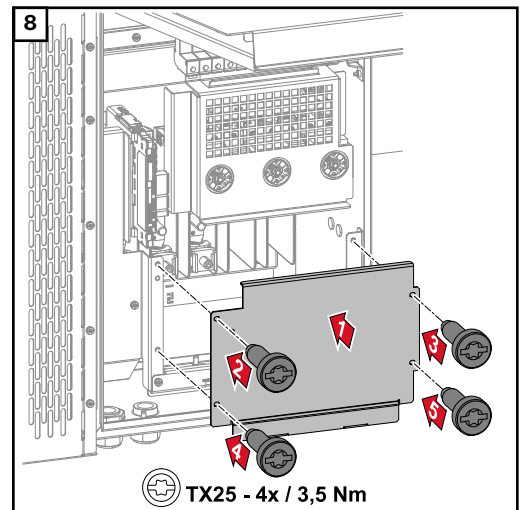
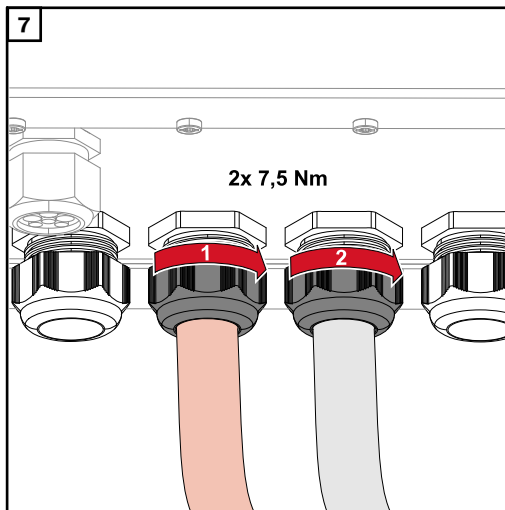
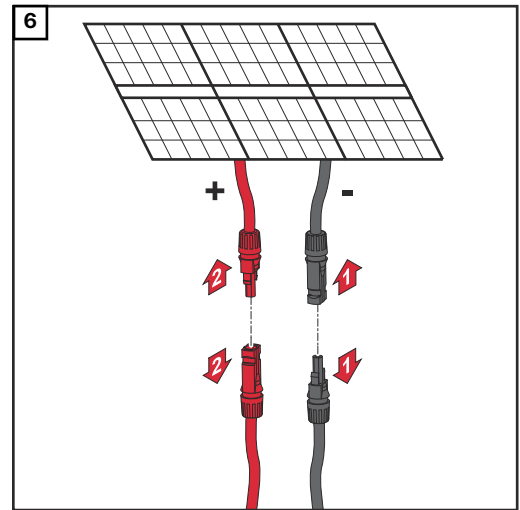
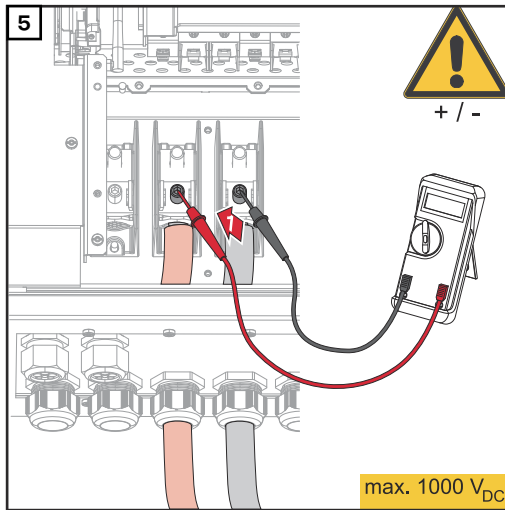

**Connecting cables with a cable lug**

Alternatively, a cable with a cable lug can be connected to the M12 threaded bolts on the grid connections in order to connect the cables to the V-type terminals.

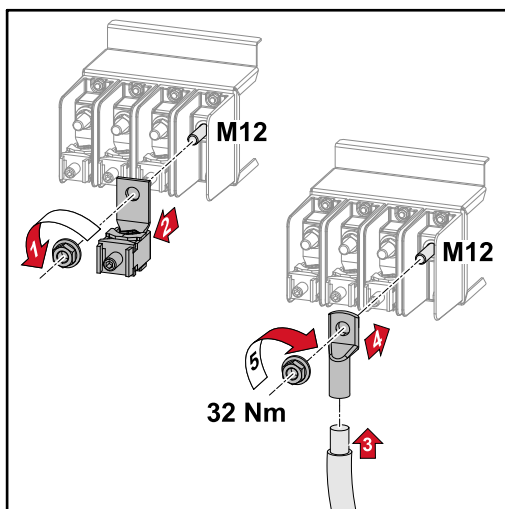

## Replacing the string fuses

### **⚠ CAUTION!**

#### **Danger due to faulty fuses.**

This can lead to fires.

- ▶ Only replace faulty fuses with new ones of the same rating.
- ▶ Do not replace faulty fuses with bolts.

### **⚠ CAUTION!**

#### **Danger due to incorrectly dimensioned string fuses**

Incorrectly dimensioned string fuses can cause damage to the inverter for these connected components.

The following string fuses should be used for the -D (direct) version of the Fronius Tauro:

- ▶ Max. **10 A** per string → use of **15 A gPV fuse 1000 V** possible (Fronius item number: 41,0007,0230 - fuse 15 1000 F PV 15A)
- ▶ Max. **14.5 A** per string → use of **20 A gPV fuse 1000V** required (Fronius item number: 41,0007,0233 - fuse-HL 20A 1KV fast)
- ▶ Max. **22 A** per string → use of **30 A gPV fuse 1000V** required (Fronius item number: 41,0007,0241 - fuse-HL 30A 1KV fast)

#### **Replacing fuses:**

**Fronius Tauro 50-3-D string 1.1 - 3.7 /**

**Fronius Tauro 50-3-D (30A fuses) string 1.1 - 3.5 /**

**Fronius Tauro Eco 50-3-D string 1.1 - 2.7 /**

**Tauro Eco 50-3-D (30A fuses) string 1.1 - 2.5 /**

**Fronius Tauro Eco 99 / 100-3-D string 1.1 - 2.7 /**

**Fronius Tauro Eco 99 / 100-3-D (30A fuses) string 1.1 - 3.5**

Check values! Only replace faulty fuses with new ones of the same rating.

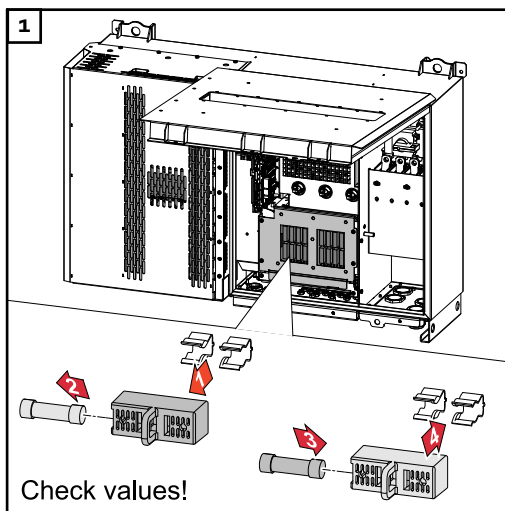

**Replacing fuses:**

**Fronius Tauro Eco 99 / 100-3-D string 3.1 - 3.8**

Check values! Only replace faulty fuses with new ones of the same rating.

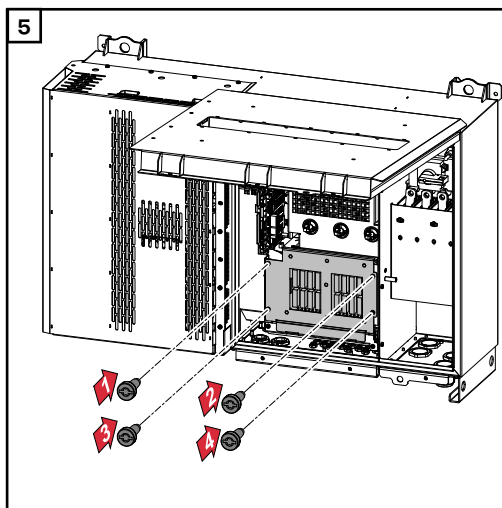
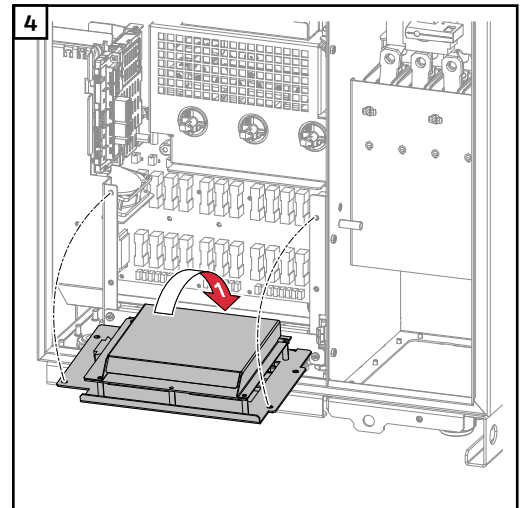
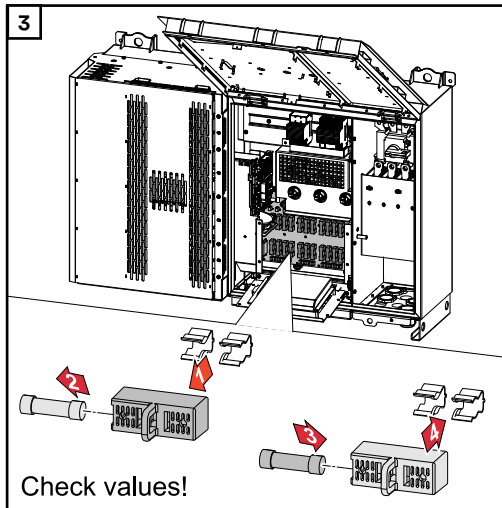
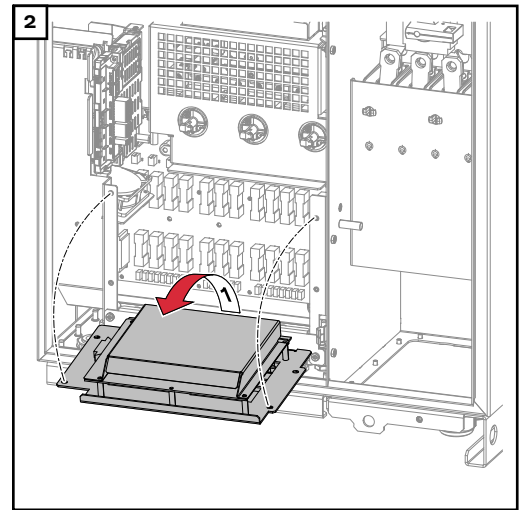
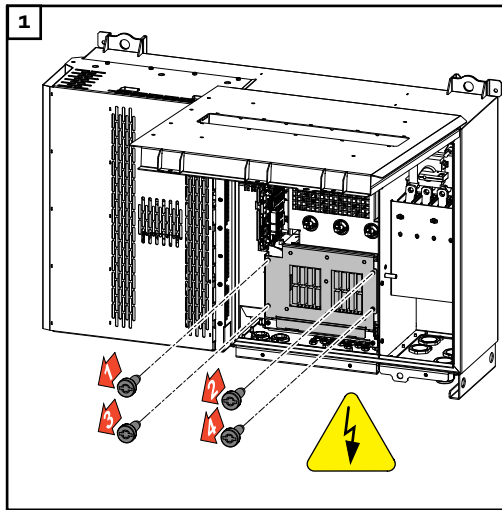

Closing and switching on the inverter

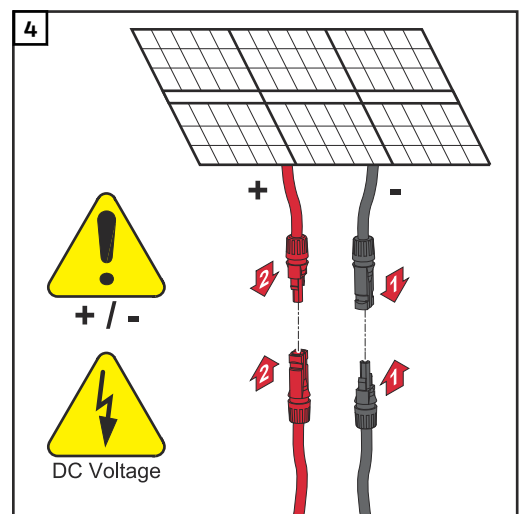
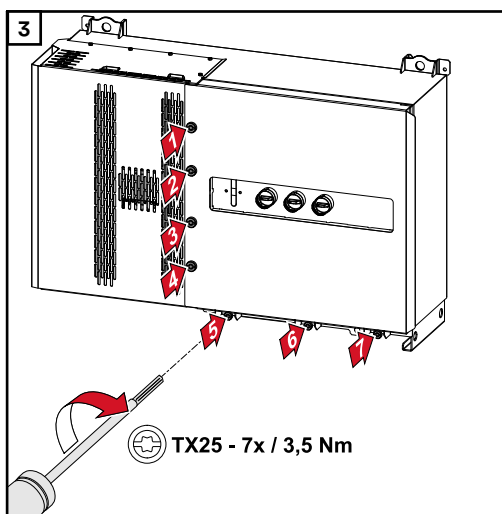
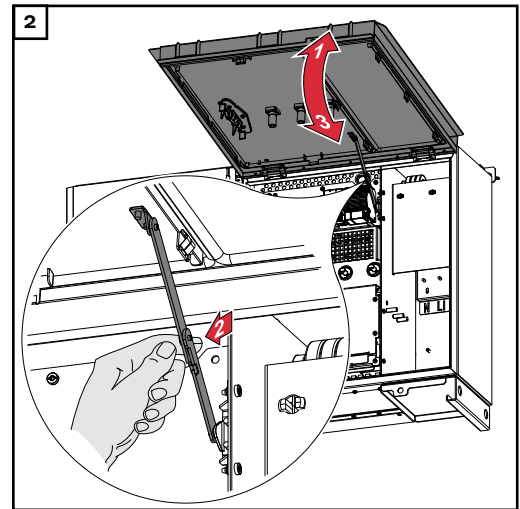
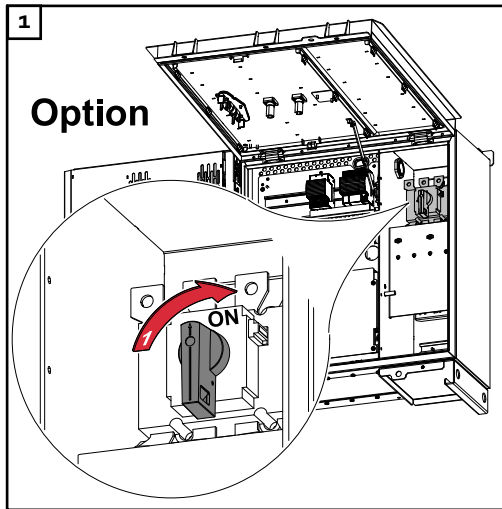

**WARNING!**

**Danger due to DC disconnectors that are not switched on properly**

This can result in serious injury and damage to property.

- ▶ Turn all existing DC disconnectors to the ON position before turning on the AC connection.
- ▶ The DC disconnectors may only ever be actuated simultaneously (one immediately after the other).

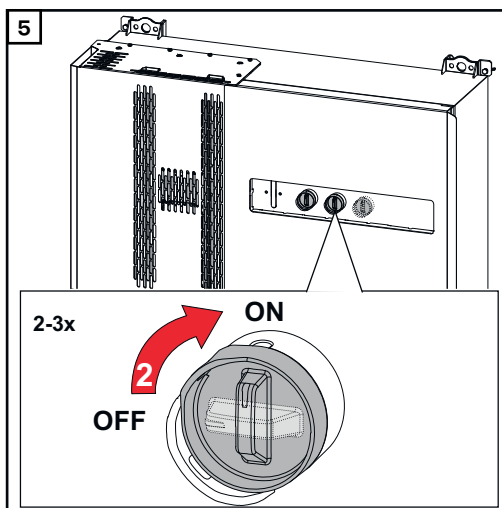

The WLAN access point can be opened with the optical sensor, see chapter [Button functions and LED status indicator](#) on page 25

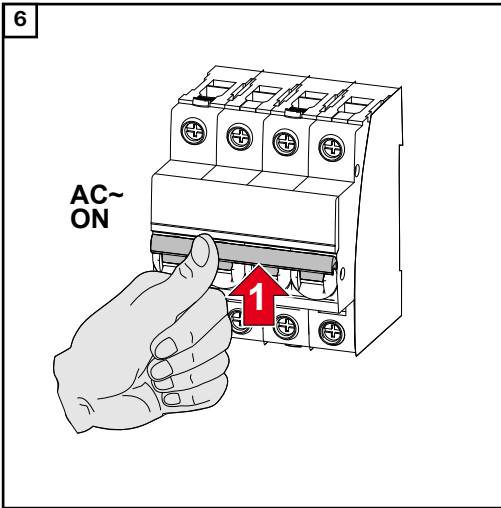

# Connecting the data communication cable

## Modbus participants

The inputs M0 and M1 can be freely selected. A maximum of 4 Modbus participants can be connected to the Modbus terminal on inputs M0 and M1..

### IMPORTANT!

If the function „Inverter control via Modbus“ is activated in the menu area „Communication“ → „Modbus“, no Modbus participants are possible. It is not possible to send and receive data at the same time.

## Permitted cables for the data communication area

Cables with the following design can be connected to the terminals of the inverter:



- Copper: round, solid



- Copper: round, fine-stranded

WSD connections with push-in terminal						
Distance max.	Stripping length	Solid	Fine-stranded	Fine-stranded with ferrules with collar	Fine-stranded with ferrules without collar	Cable recommendation
100 m	10 mm	0.14 - 1.5 mm <sup>2</sup>	0.14 - 1.5 mm <sup>2</sup>	0.14 - 1 mm <sup>2</sup>	0.14 - 1.5 mm <sup>2</sup>	min. CAT 5 UTP

Modbus connections with push-in terminal						
Distance max.	Stripping length	Solid	Fine-stranded	Fine-stranded with ferrules with collar	Fine-stranded with ferrules without collar	Cable recommendation
300 m	10 mm	0.14 - 1.5 mm <sup>2</sup>	0.14 - 1.5 mm <sup>2</sup>	0.14 - 1 mm <sup>2</sup>	0.14 - 1.5 mm <sup>2</sup>	min. CAT 5 STP

IO connections with push-in terminal						
Distance max.	Stripping length	Solid	Fine-stranded	Fine-stranded with ferrules with collar	Fine-stranded with ferrules without collar	Cable recommendation
30 m	10 mm	0.14 - 1.5 mm <sup>2</sup>	0.14 - 1.5 mm <sup>2</sup>	0.14 - 1 mm <sup>2</sup>	0.14 - 1.5 mm <sup>2</sup>	Single conductor possible

## LAN connections

Fronius recommends at least CAT 5 STP (Shielded Twisted Pair) cables and a maximum distance of 100 m.

### Multiple inverters in one network

The network cabling of the inverters must be in a star arrangement. Observe the maximum lengths and requirements for the cable!

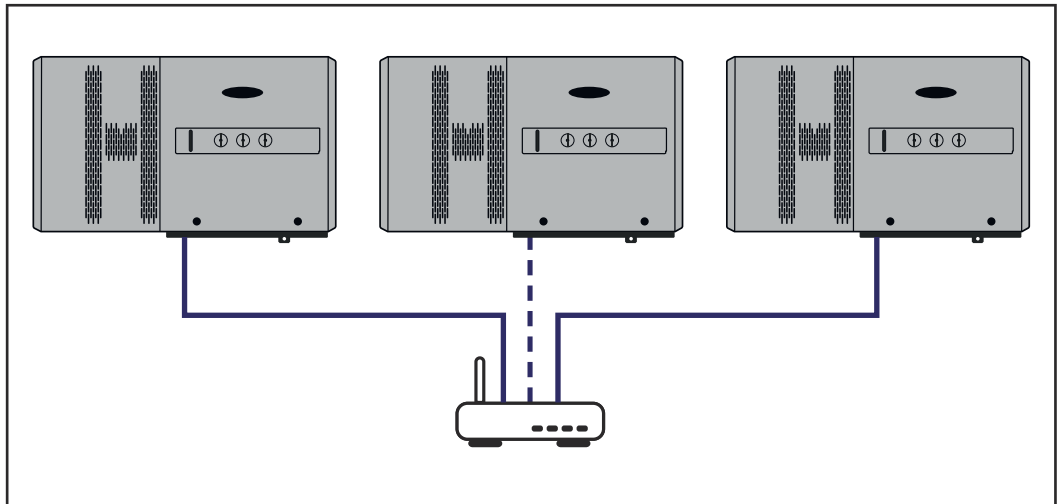

### Routing data communication cables

To use the connection to Fronius Solar.web or Modbus TCP, each Tauro must be connected directly to the network via LAN.

**IMPORTANT!** If data communication cables are wired into the inverter, observe the following points:

- Depending on the number and cross section of the wired data communication cables, remove the corresponding blanking plugs from the sealing insert and insert the data communication cables.
- Make sure that you insert the corresponding blanking plugs into any free openings on the sealing insert.

**Note!** Should the blanking plugs be missing or improperly fitted, then protection class IP65 cannot be guaranteed.

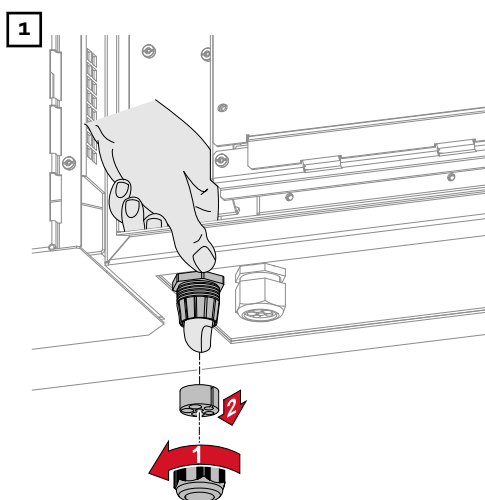

Undo the strain-relief device cap nut and push out the sealing ring and the blanking plug from the inside of the device.

2

3x Ø4,9-5,5mm (0.19-0.22inch)  
3x Ø6,7-8,5mm (0.26-0.33inch)

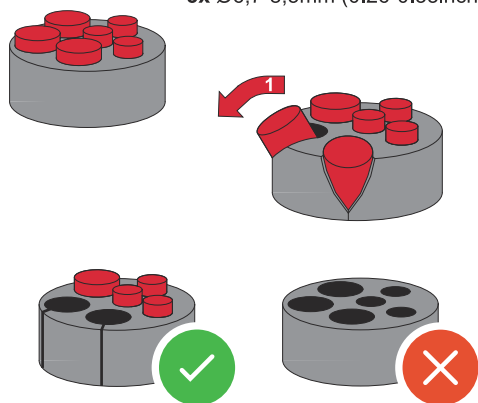

Open up the sealing ring at the location where the blanking plug is to be removed.

\* Liberate the blanking plug by moving it sideways.

3

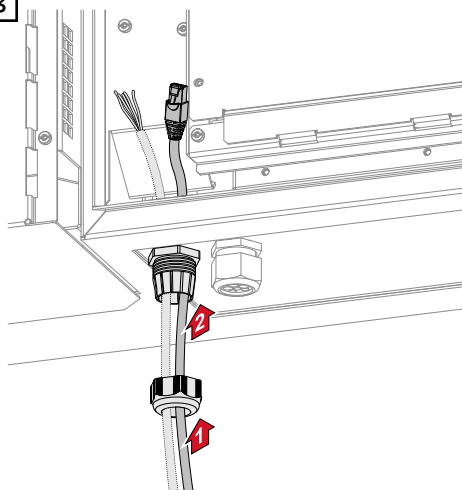

Guide the data cables first through the strain-relief device cap nut and then through the housing opening.

4

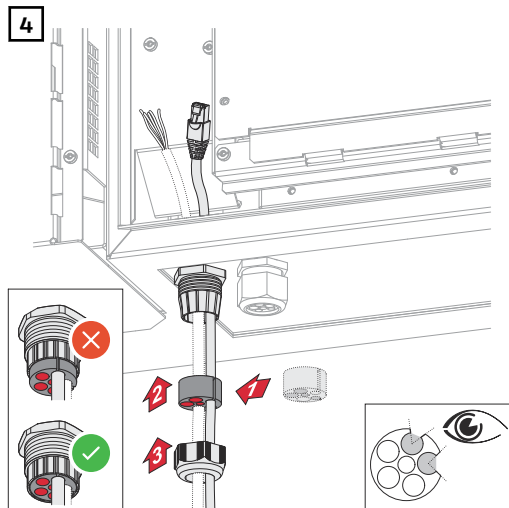

Insert the sealing ring between the cap nut and the housing opening. Press the data cables into the seal's cable guide. Then press in the seal until it reaches the underside of the strain-relief device.

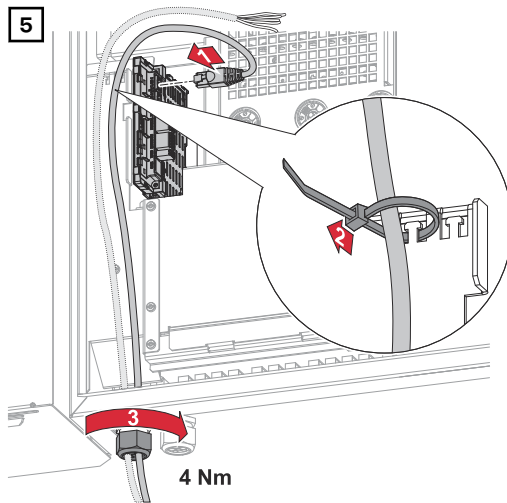

Connect the data cables to the data communication area using a movement loop, and fasten the cap nut with min. 2.5 to max. 4 Nm.

### WSD (wired shutdown)

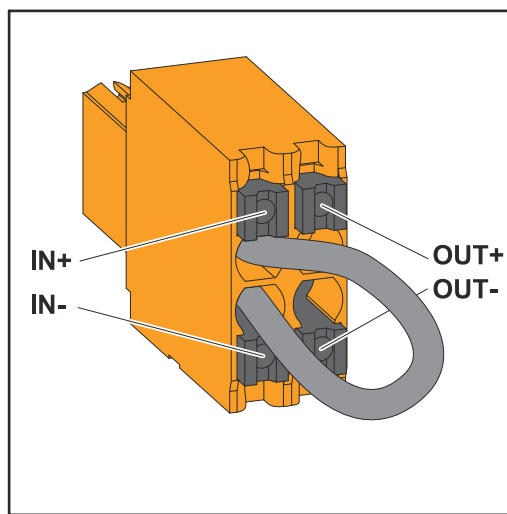

### IMPORTANT!

The push-in WSD terminal in the inverter's connection area is delivered with a bypass ex works as standard. The bypass must be removed when installing a trigger device or a WSD chain.

The WSD switch of the first inverter with connected trigger device in the WSD chain must be in position 1 (primary device). The WSD switch of all other inverters should be in the 0 (secondary device) position.

Max. distance between two devices: 100 m  
Max. number of devices: 28

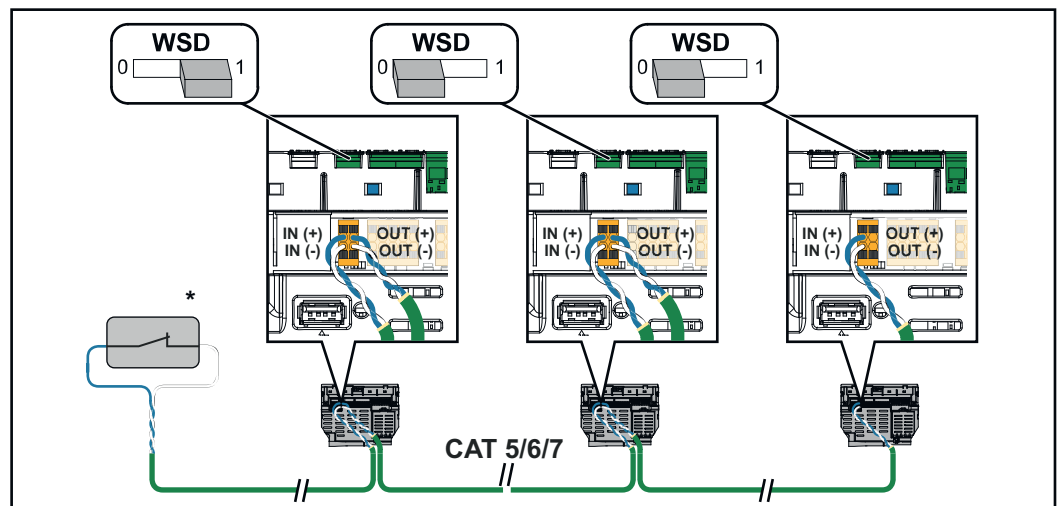

\* Floating contact of the trigger device (e.g. central grid and system protection).  
If several floating contacts are used in a WSD chain, they must be connected in series.

# Using for the first time

## Starting the inverter for the first time

When starting the inverter for the first time, various setup settings must be configured.

If the setup process is cancelled before the process is complete, any data that has been input up to this point is lost and the start screen with the installation wizard is shown again. If the process is interrupted, such as in the event of a power outage, the data is saved. Commissioning may be continued from the point at which the process was interrupted once the power supply has been restored. If the setup was interrupted, the inverter feeds energy into the grid at maximum 500 W and the operating status LED flashes yellow.

The country setup can only be set when starting the inverter for the first time. If the country setup needs to be changed at a later date, please contact your installer / Technical Support team.

## Fronius system monitoring (Pilot) display

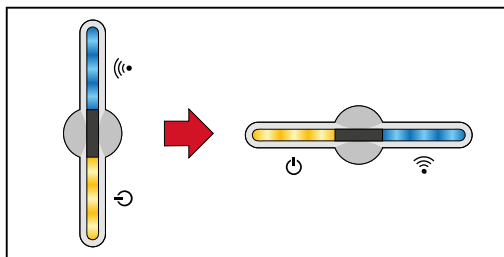

To simplify the display, the vertical installation position of the Pilot pc board (LED display) is shown horizontally below.

## Installation mit der App

Für die Installation wird die App „Fronius Solar.start“ benötigt. Abhängig von dem Endgerät, mit dem die Installation durchgeführt wird, ist die App auf der jeweiligen Plattform erhältlich.

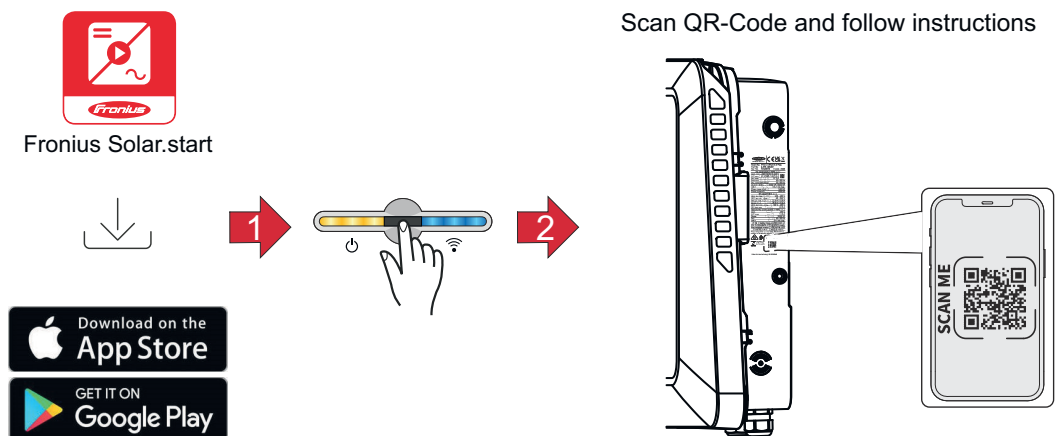

- 1 Die Fronius Solar.start App herunterladen und installieren.
- 2 Den Access Point durch Berühren des Sensors  öffnen → Kommunikations-LED blinkt blau.
- 3 Den QR-Code am Leistungsschild mit Smartphone oder Tablet scannen.
- 4 Dem Installationsassistenten in den einzelnen Bereichen folgen und die Installation abschließen.

- 5 Systemkomponenten im Solar.web hinzufügen und die PV-Anlage in Betrieb nehmen.

Der Netzwerk-Assistent und das Produkt-Setup können unabhängig voneinander durchgeführt werden. Für den Solar.web Installations-Assistenten wird eine Netzwerk-Verbindung benötigt.

### Installation using the web browser

#### WLAN:

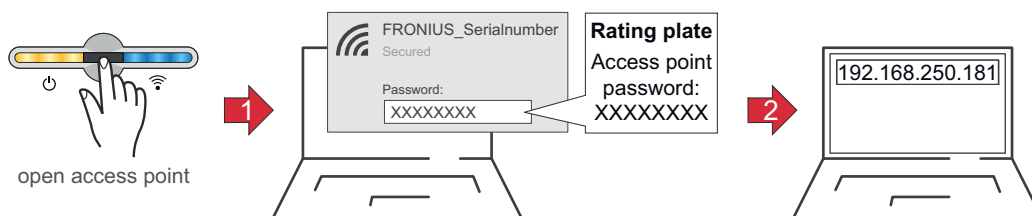

- 1 Open the access point by touching the sensor → Communication LED flashes blue.
- 2 Establish the connection to the inverter in the network settings (the inverter is displayed with the name "FRONIUS\_" and the serial number of the device).
- 3 Enter the password from the rating plate and confirm.  
**IMPORTANT!**  
To enter the password on a Windows 10 operating system, the link "Connect using a security key instead" must first be activated to establish a connection with the password.
- 4 In the browser address bar, enter and confirm the IP address 192.168.250.181. The installation wizard is opened.
- 5 Follow the installation wizard in the individual sections and complete the installation.
- 6 Add system components in Solar.web and start up the PV system.

The network wizard and the product setup can be carried out independently of each other. A network connection is required for the Solar.web installation wizard.

#### Ethernet:

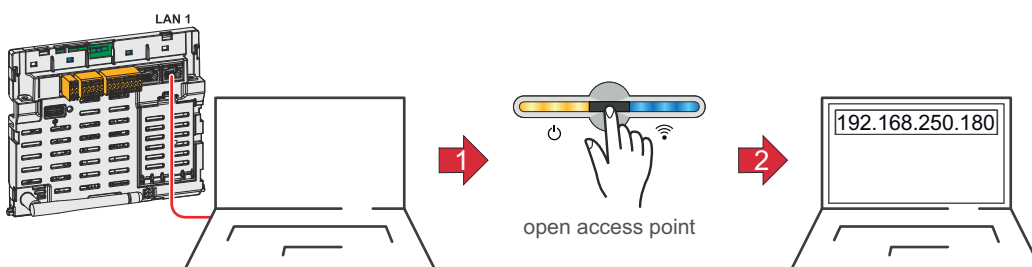

- 1 Establish a connection to the inverter (LAN1) with a network cable (CAT5 STP or higher).
- 2 Open the access point by touching the sensor once → Communication LED: flashes blue.
- 3 In the browser address bar, enter and confirm IP address 169.254.0.180. The installation wizard is opened.
- 4 Follow the installation wizard in the individual sections and complete the installation.

- 5 Add system components in Solar.web and start up the PV system.

The network wizard and the product setup can be carried out independently of each other. A network connection is required for the Solar.web installation wizard.

# Switching off current supply and restarting the inverter

De-energising the inverter and switching it on again

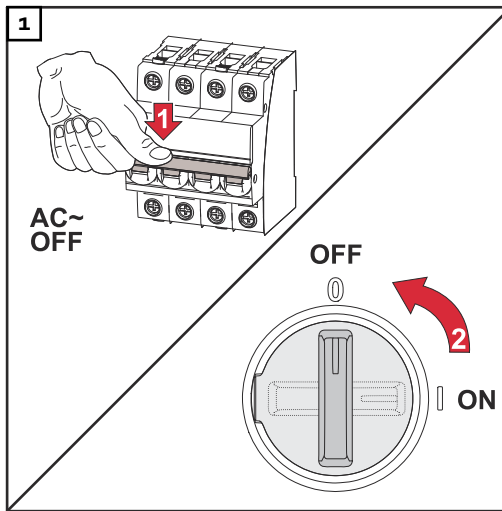

1. Turn off the automatic circuit breaker.
2. Turn the DC disconnecter to the "Off" switch position.

To start up the inverter again, follow the steps listed above in reverse order.



# **Settings - user interface of the in- verter**



# User settings

---

## User login

- 1 Open the user interface of the inverter in your browser.
- 2 In the "**Login**" menu, log in using your user name and password, or go to the "**User**" menu and click on the "**User login**" button and then log in with your user name and password.

### **IMPORTANT!**

Depending on the user's authorization, settings can be executed in the individual menus.

---

## Selecting the language

- 1 In the "**User**" menu, click on the "**Language**" button and select the desired language.

# Device configuration

## Components

Select "**Add component+**" to add all available components to the system.

### PV generator

Activate the particular PV generator and enter the connected PV power in the associated field.

### Primary meter

To ensure smooth operation in conjunction with other energy producers, it is important to install the Fronius Smart Meter at the feed-in point. The inverter and other producers must be connected to the public grid via the Fronius Smart Meter.

This setting also affects how the inverter behaves overnight. If the function is deactivated, the inverter switches to standby mode as soon as there is no more PV power available. The message "Power low" is displayed. The inverter starts again as soon as sufficient PV power is available.

After connecting the meter, the position must be configured.

Several Fronius Smart Meters can be installed in the system. A different address needs to be set for each Smart Meter.

The Watt value on the generator meter is the sum of all generator meters. The Watt value on the consumption meter is the value of all consumption meters.

### Ohmpilot

All Ohmpilots available in the system are displayed. Select the desired Ohmpilot and add it to the system via "**Add**".

## Functions and IOs

### Load management

Up to four pins can be selected here for load management. Other load management settings are available in the Load Management menu item.

Default: Pin 1

### OFF - Demand Response Mode (DRM)

The pins for control via DRM can be set here:

Mode	Description	Information	De-fault pin
DRM0	Inverter disconnects itself from the grid	Open grid relay	
	REF GEN		RGO
	COM LOAD		CLO
		DRM0 occurs if there is an interruption or short circuit on the REF GEN or COM LOAD leads. Or if the combinations DRM1 - DRM8 are invalid.	

**IMPORTANT!**

If the Demand Response Mode (DRM) function is enabled and no DRM control is connected, the inverter switches to Standby mode.

---

**"PSC editor - AUS - Demand Response Modes (DRM)"**

A value for the apparent power consumption and apparent power output can be entered here for the Australia country setup.

---

**Demand Response Modes (DRM)**

Here you can enter a value for the apparent power input and the apparent power output for the Australia country setup.

---

**Inverter**
**"Enforce Standby"**

When the function is activated, the feed-in mode of the inverter is interrupted. This enables a powerless shutdown of the inverter and protects its components. When the inverter is restarted, the standby function is automatically deactivated.

**"PV 1" and "PV 2"**

Parameter	Value range	Description
<b>"Mode"</b>	Off	The MPP tracker is deactivated.
	Auto	The inverter uses the voltage at which the max. possible power of the MPP tracker is possible.
	Fix	The MPP tracker uses the voltage defined in the <b>"UDC fix"</b> .
<b>"UDC fix"</b>	80 - 530 V	The inverter uses the fixed preset voltage used at the MPP tracker.
<b>"Dynamic Peak Manager"</b>	Off	The function is deactivated.
	On	The entire solar module string is checked for optimisation potential and determines the best possible voltage for feed-in mode.

**"Ripple Control"**

Ripple control signals are signals sent out by the energy company to switch controllable loads on and off. Depending on the installation situation, ripple control signals may be attenuated or amplified by the inverter. The settings below can be used to counteract this if necessary.

Parameter	Value range	Description
<b>"Reduction of Influence"</b>	Off	The function is deactivated.
	On	The function is activated.
<b>"Frequency of Ripple Control Signal"</b>	100 - 3000 Hz	The frequency specified by the energy company must be entered here.
<b>"Grid Inductance"</b>	0.00001 - 0.005 H	The value measured at the feed-in point must be entered here.

**"Measures against RCD/RCMU false trips"**  
 (when using a 30 mA residual current circuit breaker)

Parameter	Value range	Description
"Inverter shut-down before 30 mA RCD trips"	0	No measures to prevent false tripping.
	1	The inverter switches off at 15 mA before the residual current circuit breaker trips.

**"Iso Warning"**

Parameter	Value range	Description
"Iso Warning"	Off	The isolation warning is deactivated.
	On	The isolation warning is activated. A warning is issued in the event of an isolation fault.
"Iso Alternative Mode"	Accurate	Isolation monitoring is performed with the highest accuracy and the measured insulation resistance is displayed on the user interface of the inverter.
	Fast	Isolation monitoring is performed with lower accuracy, which shortens the duration of the isolation measurement, and the isolation value is not displayed on the user interface of the inverter.
"Isolation Warning Threshold"	10 - 10,000 kΩ	If this threshold is undershot, status code 1083 is displayed on the user interface of the inverter.

## General

### General settings

- 1 In the "**System name**" input field, enter the name of the system (max. 30 characters).
- 2 "**Synchronize time automatically**" enabled → select "Area time zone" and "Location time zone". The date and time are applied from the time zone entered.
- 2 "**Synchronize time automatically**" disabled → enter or select "Date", "Time", "Area time zone" and "Location time zone".
- 3 Click on the "**Save**" button.

## Update

All available updates are made available on the product page and in the "Download search" area under [www.fronius.com](http://www.fronius.com) .

### Firmware update

- 1 Drag the firmware file into the "Drag&Drop file here" field or select it using "Select file".

The update will start.

## Setup wizard

The guided setup wizard can be accessed here.

## Restoring the factory settings

### All settings

All configuration data is reset with the exception of the country setup. Changes to the country setup may only be carried out by authorized personnel.

### All settings with no network

All configuration data is reset with the exception of the country setup and the network settings. Changes to the country setup may only be carried out by authorized personnel.

## Event Log

### Current Messages

All current events of the connected system components are shown here.

### IMPORTANT!

Depending on the type of event, these must be confirmed via the "tick" button in order to be processed further.

### History

All events of the connected system components that no longer exist are shown here.

## Information

This menu displays all system information and the current settings.

### Save as PDF

- 1 Click on the "Save as PDF" button.
- 2 Individually select information with the "tick" next to the information or tick to "Select all".
- 3 Enter the file name in the input field and click on the "Save" button.

The PDF is created and displayed.

---

### License Manager

The licence file contains the performance data and the scope of functions of the inverter. When replacing the inverter, power stage set or data communication area, the licence file must also be replaced.

#### Licensing - online (recommended):

An Internet connection and completed configuration on Solar.web is required.

- 1 Complete the installation work (see chapter [Starting the inverter for the first time](#) on page [68](#)).
- 2 Connect to the user interface of the inverter.
- 3 Enter the serial number and verification code (VCode) of the defective and replacement unit. The serial number and the VCode can be found on the rating plate of the inverter (see chapter [Warning notices and rating plate on the device](#) on page [14](#)).
- 4 Click on the "Start online licensing" button.
- 5 Skip the Terms of use and Network settings menu items by clicking on "Next".

The licence activation starts.

#### Licensing - offline:

There must be no Internet connection for this. When licensing offline with an established internet connection, the licence file is automatically uploaded to the inverter. Therefore, when uploading the licence file, the following error occurs: "The licence has already been installed and the wizard can be closed".

- 1 Complete the installation work (see chapter [Using for the first time](#) on page [68](#)).
- 2 Connect to the user interface of the inverter.
- 3 Enter the serial number and verification code (VCode) of the defective and replacement unit. The serial number and the VCode can be found on the rating plate of the inverter (see chapter [Warning notices and rating plate on the device](#) on page [14](#)).
- 4 Click on the "Start offline licensing" button.
- 5 Download the service file onto the end device by clicking on the "Download service file" button.
- 6 Open the website [licensemanager.solarweb.com](http://licensemanager.solarweb.com) and log in with your user name and password.
- 7 Drag or upload the service file into the "Drop service file here or click to upload" field.
- 8 Download the newly generated licence file onto the end device using the "Download license file" button.
- 9 Go to the user interface of the inverter and drag the licence file into the "Drag & drop license file here" field, or select it via "Choose license file".

The licence activation starts.

## Support

### Enable Support User

- 1 Click the "**Enable Support User**" button.

The support user is enabled.

#### **IMPORTANT!**

The support user only allows Fronius Technical Support to implement settings on the inverter via a secure connection. The button "**Terminate Support User Session**" deactivates the access.

---

### Generate support info (for Fronius Support team)

- 1 Click on the "**Generate support info**" button.
- 2 The sdp.cry file is downloaded automatically. To download manually, click on the "**Download Support-Info**" button.

The sdp.cry file is saved in the downloads.

---

### Activate Remote Access

- 1 Click on the "**Activate Remote Access**" button.

Remote maintenance access for the Fronius Support team is enabled.

#### **IMPORTANT!**

Remote maintenance access gives Fronius Technical Support exclusive access to the inverter via a secure connection. Diagnostic data is transmitted here that can be used for troubleshooting purposes. Only enable remote maintenance access following a request from the Fronius Support team.

# Communication

---

## Network

### Server addresses for data transfer

If a firewall is used for outgoing connections, the following protocols, server addresses and ports must be allowed for successful data transfer:

- Tcp fronius-se-iot.azure-devices.net:8883
- Tcp fronius-se-iot-telemetry.azure-devices.net:8883
- Tcp fronius-se-iot-telemetry.azure-devices.net:443
- Udp sera-gen24.fronius.com:1194 (213.33.117.120:1194)
- Tcp cure-se.fronius.com:443
- Tcp firmware-download.fronius.com:443
- Tcp froniuseiot.blob.core.windows.net:443
- Tcp provisioning.solarweb.com:443
- Upd/Tcp O.time.fronius.com:123

When using FRITZ!Box products, the Internet access must be configured to be unlimited and unrestricted. The DHCP Lease Time (validity) must not be set to 0 (=infinite).

---

### LAN:



#### Establishing a connection:

- 1 Enter host name.
- 2 Select connection type **"automatic"** or **"static"**.
- 3 For connection type **"static"** - enter IP address, subnet mask, DNS and gateway.
- 4 Click on the **"Connect"** button.

The connection is established. After connecting, the status of the connection should be checked (see chapter **"Internet Services"** on page 85).

---

### WLAN:



#### Establishing a connection via WPS:

- 1 Click the **"Enable"** button.
- 2 Activate WPS on the WLAN router (see documentation provided with the WLAN router).

The connection is established automatically. After connecting, the status of the connection should be checked (see chapter **"Internet Services"** on page 85).

#### Selecting and connecting to a WLAN network:

The networks found are shown in the list. Clicking on the refresh button  will carry out a second search of the available WLAN networks. The **"Find network"** input field can be used to further restrict the selection list.

- 1 Select network from the list.
- 2 Select connection type **"automatic"** or **"static"**.

- 3 For connection type "**automatic**" - enter WLAN password and host name.
- 4 For connection type "**static**" - enter IP address, subnet mask, DNS and gateway.
- 5 Click on the "**Connect**" button.

The connection is established. After connecting, the status of the connection should be checked (see chapter "**Internet Services**" on page 85).

---

#### Access point:



The inverter serves as an access point. A PC or smart device connects directly to the inverter. It is not possible to connect to the internet. The "**Network name (SSID)**" and "**Network key (PSK)**" can be assigned in this menu. It is possible to operate a connection via WLAN and via access point simultaneously.

---

## Modbus

To use the Modbus TCP or the connection to Fronius Solar.web, each Tauro must be connected directly to the network via LAN.

### Modbus RTU interface 0 / 1

If one of the two Modbus RTU interfaces is set to Slave, the following input fields are available:

---

#### "Baud rate"

The baud rate influences the transmission speed between the individual components connected in the system. When selecting the baud rate, ensure that it is the same at both the sending and receiving end.

---

#### "Parity"

The parity bit can be used to check the parity. It detects transmission errors. A parity bit can safeguard a specific number of bits. The value (0 or 1) of the parity bit must be calculated by the sender and is checked by the recipient using the same calculation. The parity bit can be calculated for even and odd parity.

---

#### "SunSpec Model Type"

Depending on the SunSpec model, there are two different settings.

**float:** SunSpec Inverter Model 111, 112, 113 or 211, 212, 213.

**int + SF:** SunSpec Inverter Model 101, 102, 103 or 201, 202, 203.

---

#### "Meter address"

---

#### "Inverter address"

---

### Slave as Modbus TCP

If the function "**Slave as Modbus TCP**" is activated, the following input fields are available:

---

#### "Modbus port"

Number of the TCP port that is to be used for Modbus communication.

---

#### "SunSpec Model Type"

Depending on the SunSpec model, there are two different settings.

**float:** SunSpec Inverter Model 111, 112, 113 or 211, 212, 213.

**int + SF:** SunSpec Inverter Model 101, 102, 103 or 201, 202, 203.

---

"Meter address"

---

#### **Inverter control via Modbus**

If this option is activated, the inverter is controlled via Modbus.

Inverter control includes the following functions:

- On/Off
- Power reduction
- Specification of a constant power factor (cos phi)
- Specification of a constant reactive power value

---

## **Remote control**

### **Remote control and Profiles**

The grid operator/energy supplier can influence the output power of the inverter by means of remote control. The prerequisite for this is for the inverter to have an active internet connection.

<b>Parameter</b>	<b>Value range</b>	<b>Description</b>
<b>Remote control</b>	Off	Remote control of the inverter is deactivated.
	On	Remote control of the inverter is activated.
<b>Allow remote control for regulatory purposes (Technician)</b>	Deactivated/ Activated	The function <b>Allow remote control for regulatory purposes</b> may be mandatory for proper operation of the system. *)
<b>Allow remote control for Virtual Power Plants (Customer)</b>	Deactivated/ Activated	If the <b>Allow remote control for regulatory purposes</b> function is enabled (technician access required), the <b>Allow remote control for Virtual Power Plants</b> function is automatically enabled and cannot be disabled. *)

#### **\*) Cloud Control**

A virtual power plant is an interconnection of several power plant operators to form a network. This network can be controlled via the cloud over the internet. The inverter must have an active internet connection for this. System data is transmitted.

---

**Fronius Solar API**

The Fronius Solar API is an Ethernet-based, open JSON interface. When enabled, IOT devices on the local network can access inverter information without authentication. For security reasons, the interface is deactivated at the factory and should not be activated if it is not required for a third-party application (e.g. EV charger, smart home solutions, etc.).

For monitoring, Fronius recommends using Fronius Solar.web instead, which provides secure access to inverter status and production information.

When performing a firmware update to version 1.14.x, the setting of the Fronius Solar API is adopted. The Solar API is activated for systems with a version below 1.14.x. Above this version it is deactivated but can be switched on and off in the menu.

---

**Internet Services**

This menu displays information about the connections and the current connection status. In case of problems with the connection, a short error description is shown.

# Safety and grid requirements

---

## Country setup

### **WARNING!**

#### **Danger due to unauthorised error analyses and repair work.**

This can result in serious injury and damage to property.

- ▶ Fault analyses and repair work on the photovoltaic system may only be carried out by installers/service technicians from authorised specialist companies in accordance with national standards and guidelines.
- 

### **NOTE!**

#### **Risk due to unauthorised access.**

Incorrectly set parameters can negatively influence the public grid and/or the inverter feeding energy into the grid, and lead to a loss of conformity with the standard.

- ▶ The parameters may only be adjusted by installers/service technicians from authorised specialist companies.
  - ▶ Do not give the access code to third parties and/or unauthorised persons.
- 

### **NOTE!**

#### **Risk due to incorrectly set parameters.**

Incorrectly set parameters can negatively influence the public grid and/or cause faults and failures on the inverter, and lead to the loss of conformity with the standard.

- ▶ The parameters may only be adjusted by installers/service technicians from authorised specialist companies.
  - ▶ The parameters may only be adjusted if the energy provider permits or requires this.
  - ▶ Only adjust the parameters taking into account the nationally applicable standards and/or directives and the specifications of the energy provider.
- 

The "Country Setup" menu area is intended exclusively for installers/service technicians from authorised specialist companies. To request the access code required for this menu area, see chapter [Requesting inverter codes in Solar.SOS](#).

The selected country setup for the respective country contains preset parameters according to the nationally applicable standards and requirements. Depending on local grid conditions and the specifications of the energy provider, adjustments to the selected country setup may be necessary.

---

## **Requesting inverter codes in Solar.SOS**

The "Country Setup" menu area is intended exclusively for installers/service technicians from authorised specialist companies. The inverter access code required for this menu area can be requested in the Fronius Solar.SOS portal.

Requesting inverter codes in Solar.SOS:

- 1** Go to [solar-sos.fronius.com](https://solar-sos.fronius.com) in a browser
- 2** Log in with your Fronius account
- 3** On the top right, click on the drop-down menu 
- 4** Select the menu item **Show inverter codes**

- 5 A contract page appears on which the request for the access code to change the grid parameters for Fronius inverters is located
- 6 Accept the Terms of use by checking **Yes, I have read and agree to the terms of use** and click **Confirm & Save**
- 7 After that, the codes can be retrieved in the drop-down menu at the top right under **Show inverter codes**

 **CAUTION!**

**Risk due to unauthorised access.**

Incorrectly set parameters can negatively influence the public grid and/or the inverter feeding energy into the grid, and lead to a loss of conformity with the standard.

- ▶ The parameters may only be adjusted by installers/service technicians from authorised specialist companies.
- ▶ Do not give the access code to third parties and/or unauthorised persons.

**Feed-in limitation**

Due to hardware restrictions, the Fronius Tauro cannot reduce the power to 0%, but only to 0.5 to 1%.

Electricity retailers or grid operators can prescribe feed-in limits for an inverter (e.g. max. 70% of the kWp or max. 5 kW). The feed-in limitation takes into account the self-consumption in the household before the power of an inverter is reduced:

There are two options for the feed-in limit:

- a) Simple power reduction of an inverter using Fronius Smart Meter
- b) Power reduction by external plant controller

The following formulas provide guidance as to which solution may apply:  
 $P_{WRn} \dots$  Inverter power n

$0\% P_{WR1} + 100\% P_{WR2} + 100\% P_{WR3} \dots \leq \text{Feed-in limit} \rightarrow \text{Solution a)}$

$0\% P_{WR1} + 100\% P_{WR2} + 100\% P_{WR3} \dots > \text{Feed-in limit} \rightarrow \text{Solution b)}$

**Solution a) - Power reduction of a single inverter.**

The specifications can be met if the prescribed feed-in limit is achieved by reducing the power of a single inverter to  $\geq 0\%$ .

*Example:*

*there are 3 inverters in a system: 1x Fronius Tauro 100 kW, 2x Fronius Tauro 50 kW. The specified feed-in limit at the transfer point must not exceed 100 kW.*

*Solution:*

*the Fronius Tauro can be regulated to 0% output power to meet the feed-in limit. The outputs of the other two inverters are not reduced and can feed in at any time without restriction.*

If the power reduction of an inverter to 0% is not sufficient, solution b) must be applied.

**Solution b) - Integration of a plant controller.**

This solution is used if the specifications of the grid operator cannot be met by limiting a single inverter, or if permanent access (e.g.: remote shutdown) is required. In this case, the integration of a PLANT CONTROLLER is recommended.

A detailed technical overview of this solution can be found at [www.fronius.com](http://www.fronius.com) under the keyword "feed-in management".

To benefit from the advantages of Fronius Solar.web, in addition to the monitoring function of the PLANT CONTROLLER SYSTEM a Fronius Smart Meter can also be installed. The integration of a Fronius Smart Meter ensures that the load and feed-in data of the PV system are visualised in Fronius Solar.web and are available for analysis.

---

## **I/O power management**

### **General**

In this menu item, settings relevant for a distribution network operator (DNO) are made. An effective power limitation in % and/or a power factor limitation can be set.

### **IMPORTANT!**

The service password must be entered in order to adjust settings in this menu item. Settings in this menu area must only be made by trained and qualified personnel.

**"Input pattern"** (assignment of individual I/Os)

- 1 click = white (contact open)
- 2 clicks = blue (contact closed)
- 3 x clicks = grey (not used)

**"Power factor (cos φ)"**

"ind" = inductive

"cap" = capacitive

**"DNO feedback"**

When the rule is enabled, output **DNO feedback** (pin 1 recommended) must be configured (e.g. for operating a signalling device).

For **"Import"** or **"Export"**, the data format \*.fpc is supported.

---

### **Control priorities**

For setting the control priorities for the ripple control signal receiver, the feed-in limitation and control via Modbus.

1 = highest priority, 3 = lowest priority

---

## **Connection diagram - 4 relay**

The ripple control signal receiver and the I/Os terminal of the inverter can be connected to one another in accordance with the connection diagram.

If the distance between the inverter and the ripple control signal receiver exceeds 10 m, at least a CAT 5 cable is recommended and the shield must be connected at one end to the push-in terminal of the data communication area (SHIELD).

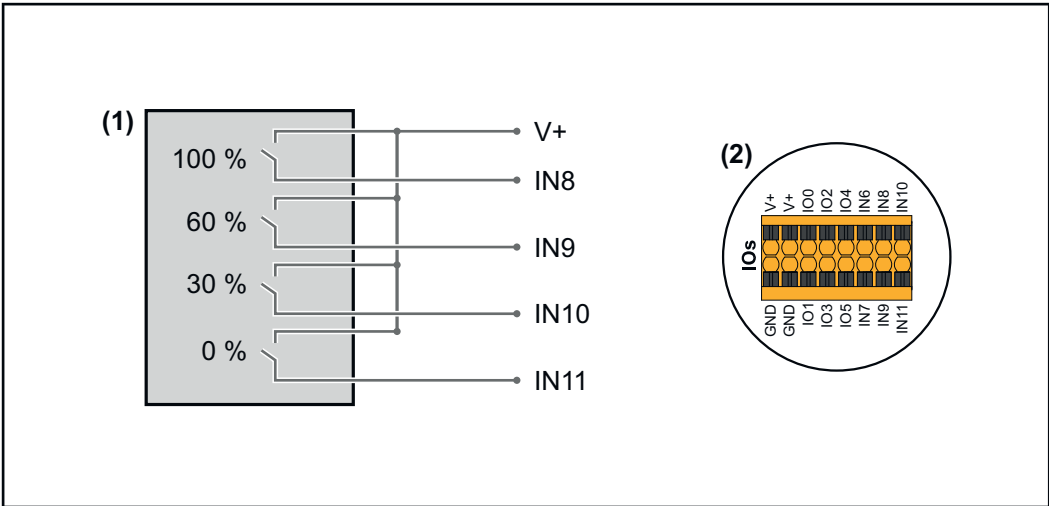

- (1) Ripple control signal receiver with 4 relays, for effective power limiting.
- (2) I/Os of the data communication area.

**Use the preconfigured file for 4-relay mode:**

- 1 Download the file (.fpc) **under 4-relay mode** onto the end device.
- 2 Upload the file (.fpc) in the **"I/O Power Management"** menu using the **"Import"** button.
- 3 Click on the **"Save"** button.

The settings for 4-relay mode are stored.

# I/O power management settings - 4 relays

## I/O Power Management

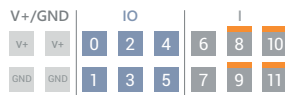

DNO Feedback  
not used

### DNO Rules

**Rule 1**

IO: 0, 2, 4, 6, 8, 10, 1, 3, 5, 7, 9, 11

Active Power: 100

Power Factor (cos φ): 1 cap

DNO Feedback:

**Rule 2**

IO: 0, 2, 4, 6, 8, 10, 1, 3, 5, 7, 9, 11

Active Power: 60

Power Factor (cos φ): 1 cap

DNO Feedback:

**Rule 3**

IO: 0, 2, 4, 6, 8, 10, 1, 3, 5, 7, 9, 11

Active Power: 30

Power Factor (cos φ): 1 cap

DNO Feedback:

**Rule 4**

IO: 0, 2, 4, 6, 8, 10, 1, 3, 5, 7, 9, 11

Active Power: 0

Power Factor (cos φ): 1 cap

DNO Feedback:

- 0 None
- 1 None
- 2 None
- 3 None
- 4 None
- 5 None
- 6 None
- 7 None
- 8 IO control
- 9 IO control
- 10 IO control
- 11 IO control

IMPORT EXPORT

**Connection diagram - 3 relay**

The ripple control signal receiver and the I/Os terminal of the inverter can be connected to one another in accordance with the connection diagram. If the distance between the inverter and the ripple control signal receiver exceeds 10 m, at least a CAT 5 cable is recommended and the shield must be connected at one end to the push-in terminal of the data communication area (SHIELD).

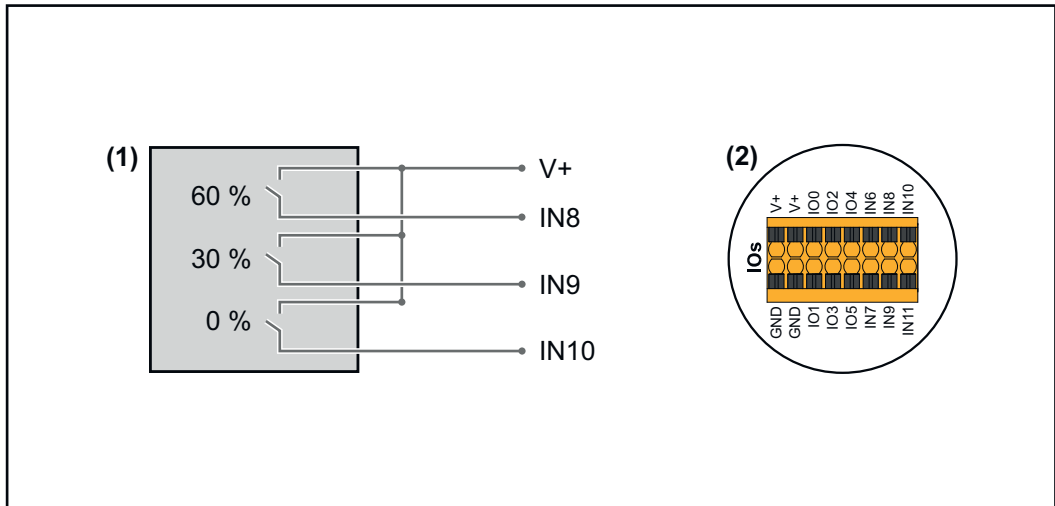

- (1) Ripple control signal receiver with 3 relays, for effective power limiting.
- (2) I/Os of the data communication area.

**Use the preconfigured file for 3-relay mode:**

- 1 Download the file (.fpc) **under 3-relay mode** onto the end device.
- 2 Upload the file (.fpc) in the "I/O Power Management" menu using the "Import" button.
- 3 Click on the "Save" button.

The settings for 3-relay mode are stored.

## I/O power management settings - 3 relays

## I/O Power Management

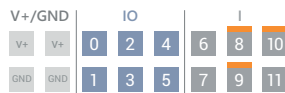

DNO Feedback  
not used

### DNO Rules

**Rule 1**

IO: 0, 2, 4, 6, 8, 10

Active Power: 100

Power Factor (cos φ): 1 cap

DNO Feedback:

**Rule 2**

IO: 0, 2, 4, 6, 8, 10

Active Power: 60

Power Factor (cos φ): 1 cap

DNO Feedback:

**Rule 3**

IO: 0, 2, 4, 6, 8, 10

Active Power: 30

Power Factor (cos φ): 1 cap

DNO Feedback:

**Rule 4**

IO: 0, 2, 4, 6, 8, 10

Active Power: 0

Power Factor (cos φ): 1 cap

DNO Feedback:

- 0 None
- 1 None
- 2 None
- 3 None
- 4 None
- 5 None
- 6 None
- 7 None
- 8 **IO control**
- 9 **IO control**
- 10 **IO control**
- 11 None

↑ IMPORT

↓ EXPORT

**Connection diagram - 2 relay**

The ripple control signal receiver and the I/Os terminal of the inverter can be connected to one another in accordance with the connection diagram. If the distance between the inverter and the ripple control signal receiver exceeds 10 m, at least a CAT 5 cable is recommended and the shield must be connected at one end to the push-in terminal of the data communication area (SHIELD).

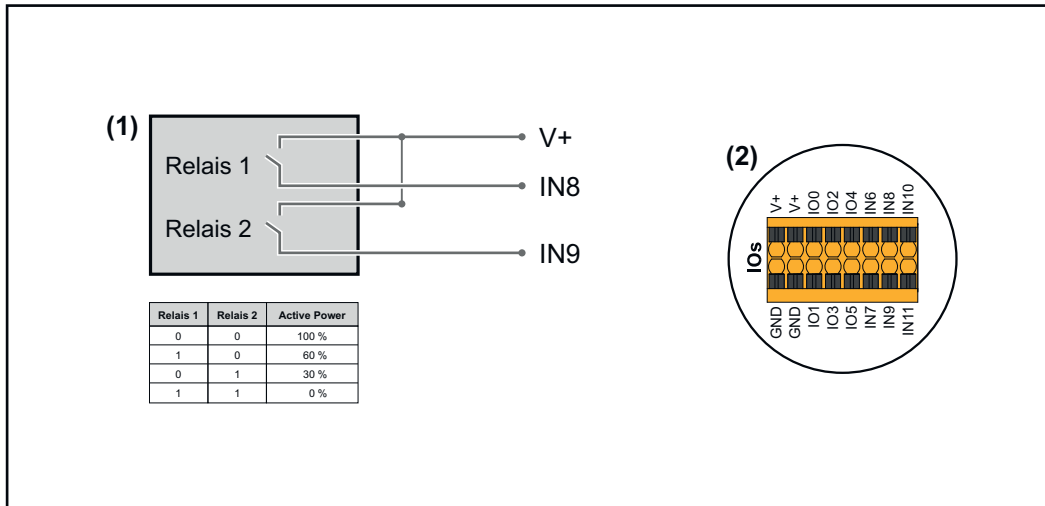

- (1) Ripple control signal receiver with 2 relays, for effective power limiting.
- (2) I/Os of the data communication area.

**Use the preconfigured file for 2-relay mode:**

- 1 Download the file (.fpc) **under 2-relay mode** onto the end device.
- 2 Upload the file (.fpc) in the **"I/O Power Management"** menu using the **"Import"** button.
- 3 Click on the **"Save"** button.

The settings for 2-relay mode are stored.

## I/O power management settings - 2 relays

## I/O Power Management

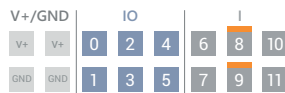

DNO Feedback  
not used

### DNO Rules

**Rule 1**

0

2

4

6

8

10

1

3

5

7

9

11

Active Power  100

Power Factor (cos φ)  1 cap

DNO Feedback

**Rule 2**

0

2

4

6

8

10

1

3

5

7

9

11

Active Power  60

Power Factor (cos φ)  1 cap

DNO Feedback

**Rule 3**

0

2

4

6

8

10

1

3

5

7

9

11

Active Power  30

Power Factor (cos φ)  1 cap

DNO Feedback

**Rule 4**

0

2

4

6

8

10

1

3

5

7

9

11

Active Power  0

Power Factor (cos φ)  1 cap

DNO Feedback

- 0 None
- 1 None
- 2 None
- 3 None
- 4 None
- 5 None
- 6 None
- 7 None
- 8 **IO control**
- 9 **IO control**
- 10 None
- 11 None

### Connection diagram - 1 relay

The ripple control signal receiver and the I/Os terminal of the inverter can be connected to one another in accordance with the connection diagram. If the distance between the inverter and the ripple control signal receiver exceeds 10 m, at least a CAT 5 cable is recommended and the shield must be connected at one end to the push-in terminal of the data communication area (SHIELD).

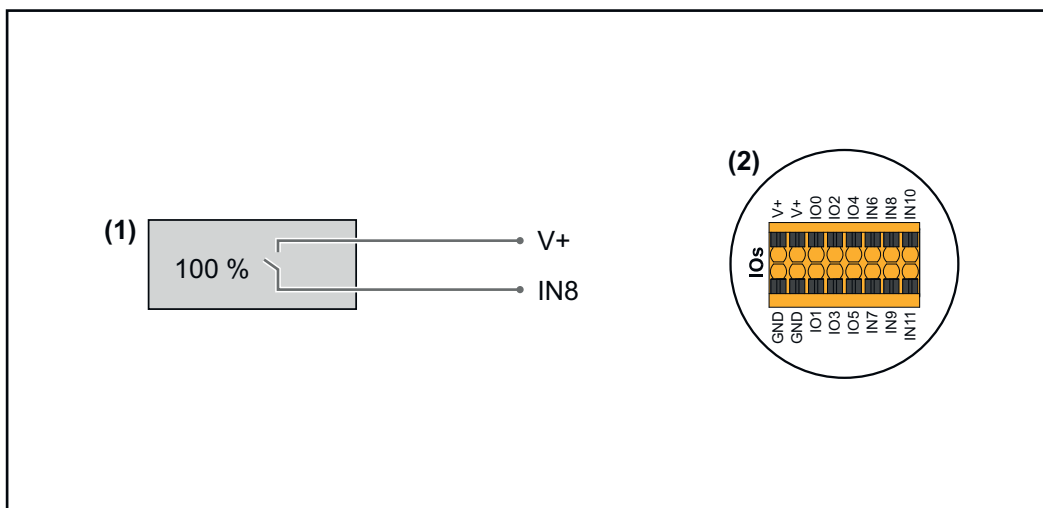

- (1) Ripple control signal receiver with 1 relay, for effective power limiting.
- (2) I/Os of the data communication area.

#### Use the preconfigured file for 1-relay mode:

- 1 Download the file (.fpc) **under 1-relay mode** onto the end device.
- 2 Upload the file (.fpc) in the "I/O Power Management" menu using the "Import" button.
- 3 Click on the "Save" button.

The settings for 1-relay mode are stored.

## I/O power management settings - 1 relay

## I/O Power Management

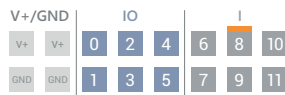

DNO Feedback  
not used

### DNO Rules

**Rule 1** ✕ ⏪ ⏩

0	2	4	6	8	10
1	3	5	7	9	11

Active Power  100

Power Factor (cos φ)  1 cap

DNO Feedback

**Rule 2** ✕ ⏪ ⏩

0	2	4	6	8	10
1	3	5	7	9	11

Active Power  0

Power Factor (cos φ)  1 cap

DNO Feedback

- 0 None
- 1 None
- 2 None
- 3 None
- 4 None
- 5 None
- 6 None
- 7 None
- 8 **IO control**
- 9 None
- 10 None
- 11 None

# Appendix



# Status codes and remedy

## Status Codes

---

### 1006 – ArcDetected (operation LED: flashes yellow)

Cause: An arc was detected at a specific point on the PV system.

Remedy: No action required. Feed-in mode is restarted again automatically after 5 minutes.

---

### 1030 - WSD Open (operation LED: lights up red)

Cause: A device connected in the WSD chain has interrupted the signal line (e.g. a surge protective device) or the bypass ex works has been removed and no trigger device has been installed.

Remedy: If the SPD surge protective device is triggered, the inverter must be repaired by an authorised specialist.

OR: Install the bypass ex works or a trigger device.

OR: Set the WSD (wired shutdown) switch to position 1 (WSD primary device).

---

## WARNING!

### Danger due to work that has been carried out incorrectly.

This can result in serious injury and damage to property.

- ▶ Installing and connecting a surge protective device (SPD) must only be carried out by service personnel trained by Fronius and only within the scope of the respective technical regulations.
- ▶ Follow the safety rules.

---

### 1173 - ArcContinuousFault (operation LED: lights up red)

Cause: An arc on the PV system was detected and the maximum number of automatic switch-ons within 24 hours was reached.

Remedy: Press and hold the sensor on the inverter for 3 seconds (max. 6 seconds).

OR: Confirm the status "**1173 - ArcContinuousFault**" in the "**System**" → "**Event Log**" menu area on the user interface of the inverter.

OR: Confirm the status "**1173 - ArcContinuousFault**" in the "**Notifications**" user menu on the user interface of the inverter.

---

## CAUTION!

### Danger from damaged components of the photovoltaic system

This can result in severe personal injury/damage to property.

- ▶ Before the status "**1173 - ArcContinuousFault**" is confirmed, the entire photovoltaic system in question must be checked for possible damage.
  - ▶ Have damaged components repaired by qualified personnel.
- 
-

# Technical data

## Tauro 50-3-D / 50-3-P

Input data	
Maximum input voltage (at 1000 W/m <sup>2</sup> / -10 °C in an open circuit)	1000 V <sub>DC</sub>
Start-up input voltage	200 V <sub>DC</sub>
MPP voltage range	400–870 V <sub>DC</sub>
Number MPP-controller	3
Maximum input current (I <sub>DC max</sub> ) Total PV1 / PV2 / PV3 per string (for D-version only)	134 A 36 A / 36 A / 72 A 14.5 A (20 A fuses) / 22 A (30A fuses)
Max. short circuit current <sup>8)</sup> Total PV1 / PV2 / PV3 per string (for D-version only)	240 A 72 A / 72 A / 125 A 20 A (20 A fuses) / 30 A (30A fuses)
Maximum PV field power (P <sub>PV max</sub> ) Total PV1 / PV2 / PV3	75 kWp 25 kWp / 25 kWp / 50 kWp
DC overvoltage category	2
Max. inverter backfeed current to the array <sup>3)</sup> D-version PV1 / PV2 / PV3 P-version PV1 / PV2 / PV3	72 / 72 / 125 A <sup>4)</sup> 0 / 0 / 0 A <sup>4)</sup>
Max. capacity of the PV generator against earth inverter	10000 nF
Max. capacity of the PV generator against earth per input PV1 / PV2 / PV3	3325 / 3325 / 6650 nF
Insulation resistance test limit value between PV generator and earth (on delivery) <sup>7)</sup>	34 kΩ
Adjustable range of insulation resistance test between PV generator and earth <sup>6)</sup>	10–10000 kΩ
Limit value and tripping time of the sudden resid- ual current monitoring (on delivery)	30 / 300 mA / ms 60 / 150 mA / ms 90 / 40 mA / ms
Limit value and tripping time of the continuous re- sidual current monitoring (on delivery)	450 / 300 mA / ms
Adjustable range of continuous residual current monitoring <sup>6)</sup>	30–1000 mA
Cyclic repetition of the insulation resistance test (on delivery)	24 h
Adjustable range for the cyclic repetition of the insulation resistance test	-
Output data	
Grid voltage range	180–270 V <sub>AC</sub>

Output data	
Rated grid voltage	220 V <sub>AC</sub>   230 V <sub>AC</sub> <sup>1)</sup>
Rated power	50 kW
Rated apparent power	50 kVA
Rated frequency	50 / 60 Hz <sup>1)</sup>
Maximum output current / Phase	76 A
Initial short-circuit current / Phase I <sub>K</sub> "	76 A
Power factor (cos phi)	0–1 ind./cap. <sup>2)</sup>
Grid connection	3~ (N)PE 380 / 220 V <sub>AC</sub> 3~ (N)PE 400 / 230 V <sub>AC</sub>
Supply earthing systems	TT (allowed, if UN_PE < 30V) TN-S (allowed) TN-C (allowed) TN-C-S (allowed) IT (not allowed)
Maximum output power	50 kW
Rated power	50 kW
Nominal output current / phase	75.8 A / 72.5 A
Total harmonic distortion	< 3%
AC overvoltage category	3
Current (inrush) <sup>5)</sup>	228 A peak / 26.6 A rms over 3.2 ms <sup>4)</sup>
Max. output fault current per period	44.7 A / 16.24 ms

General data	
Night-time power loss = standby consumption	15 W
European efficiency (400 / 600 / 800 / 870 V <sub>DC</sub> )	97.8 / 98.3 / 97.9 / 97.7%
Maximum efficiency	98.5%
Safety class	1
EMC device class	B
Pollution degree	3
Permitted ambient temperature with built-in 'AC disconnect' option	- 40 °C – +65 °C -35 °C – +65 °C
Permitted storage temperature	- 40 °C – +70 °C
Relative humidity	0–100%
Sound pressure level (600 V <sub>DC</sub> )	68.4 dB(A) (ref. 20 µPa)
Protection class	IP65
Dimensions (height x width x depth)	755 x 1109 x 346 mm
Weight	98 kg
Inverter topology	Non-insulated trans- formerless

Protection devices	
DC disconnector	Integrated
Cooling principle	Controlled forced-air ventilation
RCMU <sup>9)</sup>	Integrated
DC isolation measurement <sup>9)</sup>	Integrated <sup>2)</sup>
Overload performance	Operating point shift power limitation
Active anti-islanding method	Frequency conversion method
AFCI (for D-version with 15/20 A fuses only)	Optional
AFPE (AFCI) classification (acc. IEC63027) <sup>9)</sup> (for D-version with 15/20 A fuses only)	= F-I-AFPE-1-4/3/7-3 Full coverage Integrated AFPE 1 monitored string per input port 4/3/7 input ports per channel (AFD1: 4, AFD2: 3, AFD3: 7) 3 monitored channels

### Tauro Eco 50-3-D / 50-3-P

Input data	
Maximum input voltage (at 1000 W/m <sup>2</sup> / -10 °C in an open circuit)	1000 V <sub>DC</sub>
Start-up input voltage	650 V <sub>DC</sub>
MPP voltage range	580–930 V <sub>DC</sub>
Number MPP-controller	1
Maximum input current (I <sub>DC max</sub> ) Total PV1 / PV2 per string (for D-version only)	87.5 A 75 A / 75 A 14.5 A (20 A fuses) / 22 A (30A fuses)
Max. short circuit current <sup>8)</sup> Total PV1 / PV2 per string (for D-version only)	178 A 125 A / 125 A 20 A (20 A fuses) / 30 A (30A fuses)
Maximum PV field power (P <sub>PV max</sub> ) Total PV1 / PV2	75 kW <sub>p</sub> 60 kW <sub>p</sub> / 60 kW <sub>p</sub>
DC overvoltage category	2
Max. inverter backfeed current to the array <sup>3)</sup>	125 A <sup>4)</sup>
Max. capacity of the PV generator against earth inverter	10000 nF
Max. capacity of the PV generator against earth per input PV1 / PV2	7980 / 7980 nF
Insulation resistance test limit value between PV generator and earth (on delivery) <sup>7)</sup>	34 kΩ

Input data	
Adjustable range of insulation resistance test between PV generator and earth <sup>6)</sup>	10–10000 k $\Omega$
Limit value and tripping time of the sudden residual current monitoring (on delivery)	30 / 300 mA / ms 60 / 150 mA / ms 90 / 40 mA / ms
Limit value and tripping time of the continuous residual current monitoring (on delivery)	450 / 300 mA / ms
Adjustable range of continuous residual current monitoring <sup>6)</sup>	30–1000 mA
Cyclic repetition of the insulation resistance test (on delivery)	24 h
Adjustable range for the cyclic repetition of the insulation resistance test	-

Output data	
Grid voltage range	180–270 V <sub>AC</sub>
Rated grid voltage	220 V <sub>AC</sub>   230 V <sub>AC</sub> <sup>1)</sup>
Rated power	50 kW
Rated apparent power	50 kVA
Rated frequency	50 / 60 Hz <sup>1)</sup>
Maximum output current / Phase	76 A
Initial short-circuit current / Phase I <sub>K</sub> "	76 A
Power factor (cos phi)	0–1 ind./cap. <sup>2)</sup>
Grid connection	3~ (N)PE 380 / 220 V <sub>AC</sub> 3~ (N)PE 400 / 230 V <sub>AC</sub>
Supply earthing systems	TT (allowed, if UN_PE < 30V) TN-S (allowed) TN-C (allowed) TN-C-S (allowed) IT (not allowed)
Maximum output power	50 kW
Rated power	50 kW
Nominal output current / phase	75.8 A / 72.5 A
Total harmonic distortion	< 3%
AC overvoltage category	3
Current (inrush) <sup>5)</sup>	209 A peak / 30.5 A rms over 2.1 ms <sup>4)</sup>
Max. output fault current per period	37.2 A / 19.4 ms

General data	
Night-time power loss = standby consumption	15 W
European efficiency (580 / 800 / 930 V <sub>DC</sub> )	98.2 / 97.7 / 97.3%

<b>General data</b>	
Maximum efficiency	98.5%
Safety class	1
EMC device class	B
Pollution degree	3
Permitted ambient temperature with built-in 'AC disconnecter' option	- 40 °C – +65 °C -35 °C – +65 °C
Permitted storage temperature	- 40 °C – +70 °C
Relative humidity	0–100%
Sound pressure level (580 V <sub>DC</sub> )	68.5 dB(A) (ref. 20 µPa)
Protection class	IP65
Dimensions (height x width x depth)	755 x 1109 x 346 mm
Weight	80 kg
Inverter topology	Non-insulated transformerless

<b>Protection devices</b>	
DC disconnecter	Integrated
Cooling principle	Controlled forced-air ventilation
RCMU <sup>9)</sup>	Integrated
DC isolation measurement <sup>9)</sup>	Integrated <sup>2)</sup>
Overload performance	Operating point shift power limitation
Active anti-islanding method	Frequency conversion method
AFCI (for D-version with 15/20 A fuses only)	Optional
AFPE (AFCI) classification (acc. IEC63027) <sup>9)</sup> (for D-version with 15/20 A fuses only)	= F-I-AFPE-1-7/7-2 Full coverage Integrated AFPE 1 monitored string per input port 7/7 input ports per channel (AFD1: 7, AFD2: 7) 2 monitored channels

**Tauro Eco 99-3-D / 99-3-P**

<b>Input data</b>	
Maximum input voltage (at 1000 W/m <sup>2</sup> / -10 °C in an open circuit)	1000 V <sub>DC</sub>
Start-up input voltage	650 V <sub>DC</sub>
MPP voltage range	580–930 V <sub>DC</sub>
Number MPP-controller	1

Input data	
Maximum input current ( $I_{DC\ max}$ ) Total P-version PV1 / PV2 D-version PV1 / PV2 / PV3 per string (for D-version only)	175 A 100 A / 100 A 75 A / 75 A / 75 A 14.5 A (20 A fuses) / 22 A (30A fuses)
Max. short circuit current 8) P-version total D-version total PV1 / PV2 / (PV3 for D-version only) per string (for D-version only)	250 A 355 A 125 A / 125 A / 125 A 20 A (20 A fuses) / 30 A (30A fuses)
Maximum PV field power ( $P_{PV\ max}$ ) Total P-version PV1 / PV2 D-version PV1 / PV2 / PV3	150 kWp 79 kWp / 79 kWp 57 kWp / 57 kWp / 57 kWp
DC overvoltage category	2
Max. inverter backfeed current to the array 3) P-version total D-version total	125 A <sup>4)</sup> 250 A <sup>4)</sup>
Max. capacity of the PV generator against earth inverter	19998 nF
Max. capacity of the PV generator against earth per input P-version PV1 / PV2 per input D-version PV1 / PV2 / PV3	10507 / 10507 nF 7581 / 7581 / 7581 nF
Insulation resistance test limit value between PV generator and earth (on delivery) 7)	34 k $\Omega$
Adjustable range of insulation resistance test between PV generator and earth 6)	10–10000 k $\Omega$
Limit value and tripping time of the sudden resid- ual current monitoring (on delivery)	30 / 300 mA / ms 60 / 150 mA / ms 90 / 40 mA / ms
Limit value and tripping time of the continuous re- sidual current monitoring (on delivery)	900 / 300 mA / ms
Adjustable range of continuous residual current monitoring 6)	30–1000 mA
Cyclic repetition of the insulation resistance test (on delivery)	24 h
Adjustable range for the cyclic repetition of the insulation resistance test	-

Output data	
Grid voltage range	180–270 V <sub>AC</sub>
Rated grid voltage	220 V <sub>AC</sub>   230 V <sub>AC</sub> <sup>1)</sup>
Rated power	99.99 kW
Rated apparent power	99.99 kVA
Rated frequency	50 / 60 Hz <sup>1)</sup>
Maximum output current / Phase	152 A

<b>Output data</b>	
Initial short-circuit current / Phase $I_{K''}$	152 A
Power factor (cos phi)	0–1 ind./cap. <sup>2)</sup>
Grid connection	3~ (N)PE 380 / 220 V <sub>AC</sub> 3~ (N)PE 400 / 230 V <sub>AC</sub>
Supply earthing systems	TT (allowed, if UN_PE < 30V) TN-S (allowed) TN-C (allowed) TN-C-S (allowed) IT (not allowed)
Maximum output power	99.99 kW
Rated power	99.99 kW
Nominal output current / phase	151.5 A / 144.9 A
Total harmonic distortion	< 3%
AC overvoltage category	3
Current (inrush) <sup>5)</sup>	244 A peak / 27.2 A rms over 3.2 ms <sup>4)</sup>
Max. output fault current per period	93.9 A / 22 ms

<b>General data</b>	
Night-time power loss = standby consumption	15 W
European efficiency (580 / 800 / 930 V <sub>DC</sub> )	98.2 / 97.7 / 97.3%
Maximum efficiency	98.5%
Safety class	1
EMC device class	B
Pollution degree	3
Permitted ambient temperature with built-in 'AC disconnecter' option	- 40 °C – +65 °C -35 °C – +65 °C
Permitted storage temperature	- 40 °C – +70 °C
Relative humidity	0–100%
Sound pressure level (580 V <sub>DC</sub> / 930 V <sub>DC</sub> )	74.4 / 79.3 dB(A) (ref. 20 μPA)
Protection class	IP65
Dimensions (height x width x depth)	755 x 1109 x 346 mm
Weight	109 kg
Inverter topology	Non-insulated trans- formerless

<b>Protection devices</b>	
DC disconnecter	Integrated
Cooling principle	Controlled forced-air ventilation

Protection devices	
RCMU <sup>9)</sup>	Integrated
DC isolation measurement <sup>9)</sup>	Integrated <sup>2)</sup>
Overload performance	Operating point shift power limitation
Active anti-islanding method	Frequency conversion method
AFCI (for D-version with 15/20 A fuses only)	Optional
AFPE (AFCI) classification (acc. IEC63027) <sup>9)</sup> (for D-version with 15/20 A fuses only)	= F-I-AFPE-1-7/7/8-3 Full coverage Integrated AFPE 1 monitored string per in- put port 7/7/8 input ports per channel (AFD1: 7, AFD2: 7, AFD3: 8) 3 monitored channels

### Tauro Eco 100-3- D / 100-3-P

Input data	
Maximum input voltage (at 1000 W/m <sup>2</sup> / -10 °C in an open circuit)	1000 V <sub>DC</sub>
Start-up input voltage	650 V <sub>DC</sub>
MPP voltage range	580–930 V <sub>DC</sub>
Number MPP-controller	1
Maximum input current (I <sub>DC max</sub> ) Total P-version PV1 / PV2 D-version PV1 / PV2 / PV3 per string (for D-version only)	175 A 100 A / 100 A 75 A / 75 A / 75 A 14.5 A (20 A fuses) / 22 A (30A fuses)
Max. short circuit current <sup>8)</sup> P-version total D-version total PV1 / PV2 / (PV3 for D-version only) per string (for D-version only)	250 A 355 A 125 A / 125 A / 125 A 20 A (20 A fuses) / 30 A (30A fuses)
Maximum PV field power (P <sub>PV max</sub> ) Total P-version PV1 / PV2 D-version PV1 / PV2 / PV3	150 kWp 79 kWp / 79 kWp 57 kWp / 57 kWp / 57 kWp
DC overvoltage category	2
Max. inverter backfeed current to the array <sup>3)</sup> P-version total D-version total	125 A <sup>4)</sup> 250 A <sup>4)</sup>
Max. capacity of the PV generator against earth inverter	20000 nF

Input data	
Max. capacity of the PV generator against earth per input P-version PV1 / PV2 per input D-version PV1 / PV2 / PV3	10507 / 10507 nF 7581 / 7581 / 7581 nF
Insulation resistance test limit value between PV generator and earth (on delivery) <sup>7)</sup>	34 kΩ
Adjustable range of insulation resistance test between PV generator and earth <sup>6)</sup>	10–10000 kΩ
Limit value and tripping time of the sudden residual current monitoring (on delivery)	30 / 300 mA / ms 60 / 150 mA / ms 90 / 40 mA / ms
Limit value and tripping time of the continuous residual current monitoring (on delivery)	900 / 300 mA / ms
Adjustable range of continuous residual current monitoring <sup>6)</sup>	30–1000 mA
Cyclic repetition of the insulation resistance test (on delivery)	24 h
Adjustable range for the cyclic repetition of the insulation resistance test	-

Output data	
Grid voltage range	180–270 V <sub>AC</sub>
Rated grid voltage	220 V <sub>AC</sub>   230 V <sub>AC</sub> <sup>1)</sup>
Rated power	100 kW
Rated apparent power	100 kVA
Rated frequency	50 / 60 Hz <sup>1)</sup>
Maximum output current / Phase	152 A
Initial short-circuit current / Phase I <sub>K</sub> "	152 A
Power factor (cos phi)	0–1 ind./cap. <sup>2)</sup>
Grid connection	3~ (N)PE 380 / 220 V <sub>AC</sub> 3~ (N)PE 400 / 230 V <sub>AC</sub>
Supply earthing systems	TT (allowed, if UN_PE < 30V) TN-S (allowed) TN-C (allowed) TN-C-S (allowed) IT (not allowed)
Maximum output power	100 kW
Rated power	100 kW
Nominal output current / phase	151.5 A / 144.9 A
Total harmonic distortion	< 3%
AC overvoltage category	3
Current (inrush) <sup>5)</sup>	244 A peak / 27.2 A rms over 3.2 ms <sup>4)</sup>
Max. output fault current per period	93.9 A / 22 ms

General data	
Night-time power loss = standby consumption	15 W
European efficiency (580 / 800 / 930 V <sub>DC</sub> )	98.2 / 97.7 / 97.3%
Maximum efficiency	98.5%
Safety class	1
EMC device class	B
Pollution degree	3
Permitted ambient temperature with built-in 'AC disconnecter' option	- 40 °C – +65 °C -35 °C – +65 °C
Permitted storage temperature	- 40 °C – +70 °C
Relative humidity	0–100%
Sound pressure level (580 V <sub>DC</sub> / 930 V <sub>DC</sub> )	74.4 / 79.3 dB(A) (ref. 20 μPA)
Protection class	IP65
Dimensions (height x width x depth)	755 x 1109 x 346 mm
Weight	109 kg
Inverter topology	Non-insulated trans- formerless

Protection devices	
DC disconnector	Integrated
Cooling principle	Controlled forced-air ventilation
RCMU <sup>9)</sup>	Integrated
DC isolation measurement <sup>9)</sup>	Integrated <sup>2)</sup>
Overload performance	Operating point shift power limitation
Active anti-islanding method	Frequency conversion method
AFCI (for D-version with 15/20 A fuses only)	Optional
AFPE (AFCI) classification (acc. IEC63027) <sup>9)</sup> (for D-version with 15/20 A fuses only)	= F-I-AFPE-1-7/7/8-3 Full coverage Integrated AFPE 1 monitored string per in- put port 7/7/8 input ports per channel (AFD1: 7, AFD2: 7, AFD3: 8) 3 monitored channels

## WLAN

WLAN	
Frequency range	2412–2462 MHz

<b>WLAN</b>	
Channels / power used	Channel: 1–11 b,g,n HT20 Channel: 3–9 HT40 <18 dBm
Modulation	802.11b: DSSS (1 Mbps DBPSK, 2 Mbps DQPSK, 5.5/11 Mbps CCK) 802.11g: OFDM (6/9 Mbps BPSK, 12/18 Mbps QPSK, 24/36 Mbps 16-QAM, 48/54 Mbps 64-QAM) 802.11n: OFDM (6.5 BPSK, QPSK, 16-QAM, 64-QAM)

### Explanation of footnotes

- 1) The values stated are defaults; the inverter is configured specifically to suit the requirements of the relevant country.
- 2) Depending on the country setup or device-specific settings (ind. = inductive; cap. = capacitive).
- 3) Maximum current from a defective PV module to all other PV modules. From the inverter itself to the PV side of the inverter, it is 0 A.
- 4) Guaranteed by the electrical configuration of the inverter
- 5) Current peak when switching on the inverter
- 6) Specified values are standard values; depending on the requirement and PV power, these values must be adjusted accordingly.
- 7) Specified value is a max. value; exceeding the max. value may negatively affect the function.
- 8)  $I_{SC\ PV} = I_{CP\ PV} \geq I_{SC\ max} = I_{SC}\ (STC) \times 1,25$  according to e.g.: IEC 60364-7-712, NEC 2020, AS/NZS 5033:2021
- 9) Software class B (single channel with periodic selftest) control function according to IEC60730-1 Annex H.

### Integrated DC disconnect

<b>Settings</b>	
Product name	EATON PV-DIS-10-125/2-REFOHA
Rated insulation voltage	1000 V <sub>DC</sub>
Rated impulse withstand voltage	6 kV
Suitability for insulation	Yes, DC only
Rated operating current	Rated operating current $I_e \leq 100$ A: DC-PV2 utilisation category (as per IEC/EN 60947-3)
	Rated operating current $I_e \leq 125$ A: DC-PV1 utilisation category (as per IEC/EN 60947-3)
Utilisation category and / or PV utilisation category	As per IEC/EN 60947-3 utilisation category DC-PV2 or DC-PV1

<b>Settings</b>					
Rated short-time withstand current (I <sub>cw</sub> )	Rated short-time withstand current (I <sub>cw</sub> ): 12 x I <sub>e</sub>				
Rated short-circuit making capacity (I <sub>cm</sub> )	Rated short-circuit making capacity (I <sub>cm</sub> ): 1000 A				
	Rated operating voltage (U <sub>e</sub> ) [V d.c.]	Rated operating current (I <sub>e</sub> ) [A]	I(make) / I(break) (1.5x I <sub>e</sub> ) [A]	Rated operating current (I <sub>e</sub> ) [A]	I(make) / I(break) (4x I <sub>e</sub> ) [A]
			DC-PV1		DC-PV2
Rated breaking capacity		DC-PV1		DC-PV2	
	≤ 500	125	187.5	125	500
	600	125	187.5	125	500
	800	125	187.5	125	500
	900	125	187.5	110	440
	1000	125	187.5	100	400

# Applicable standards and guidelines

---

## **CE mark**

The devices comply with all the requisite and relevant standards and guidelines that form part of the relevant EU Directive, and are therefore permitted to display the CE mark.

---

## **WLAN**

Compliance with 2014/53/EU Radio Equipment Directive (RED)

The above table of technical data lists the frequency ranges and maximum HF transmission power used by Fronius wireless products available for sale in the EU in accordance with Article 10.8 (a) and 10.8 (b) of the RED.

Fronius products must be installed and operated such that the product is always 20 cm or more away from the body.

---

## **Power failure**

The standard measurement and safety procedures integrated into the inverter ensure that in the event of a grid failure, the feeding in of energy is immediately interrupted (e.g. switch-off by the energy supplier or damage to lines).

# Service, warranty terms and conditions and disposal

---

## **Fronius SOS**

At [sos.fronius.com](https://sos.fronius.com) you can call up warranty and device information at any time, start troubleshooting on your own and request replacement components.

For more information on spare parts, contact your installer or PV system contact person.

---

## **Fronius manufacturer's warranty**

Detailed, country-specific warranty terms are available on the internet: [www.fronius.com/solar/warranty](https://www.fronius.com/solar/warranty)

To obtain the full warranty period for your newly installed Fronius inverter or storage system, please register at: [www.solarweb.com](https://www.solarweb.com).

---

## **Disposal**

The manufacturer, Fronius International GmbH, will take back the old device and arrange for it to be recycled in an appropriate manner. Observe the national regulations for the disposal of electronic equipment.







[fronius.com/en/solar-energy/installers-partners/products-solutions/monitoring-digital-tools](https://fronius.com/en/solar-energy/installers-partners/products-solutions/monitoring-digital-tools)

**MONITORING &  
DIGITAL TOOLS**

**Fronius International GmbH**

Froniusstraße 1  
4643 Pettenbach  
Austria  
[contact@fronius.com](mailto:contact@fronius.com)  
[www.fronius.com](http://www.fronius.com)

At [www.fronius.com/contact](http://www.fronius.com/contact) you will find the contact details of all Fronius subsidiaries and Sales & Service Partners.