

**03MM-DR3006**

**Digimatch® VHF Ch.(6-12) 6 Element  
 Antenna Installation Instructions**

**Step 1**

Take both halves of the antenna out of the carton.

Swivel all elements 90 degrees to the boom from the packed position till they 'snap lock'. See diagram.

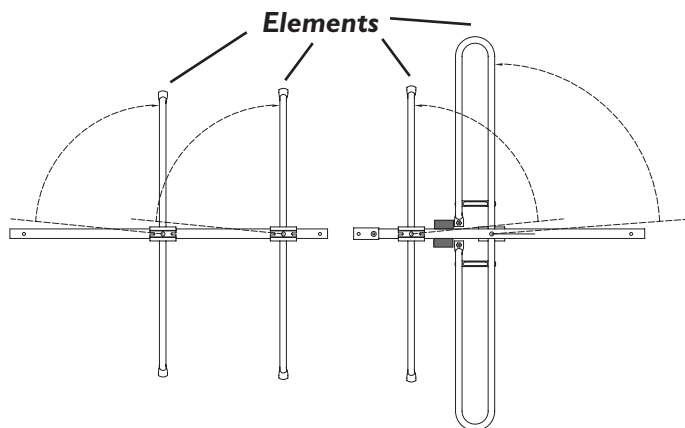

**Step 2**

Attach long loose element (900mm) to boom using the hole at the end of the boom behind the dipole.

Then attach the short loose element (530mm) onto the other section of the antenna in the hole closest to the black square boom cap.

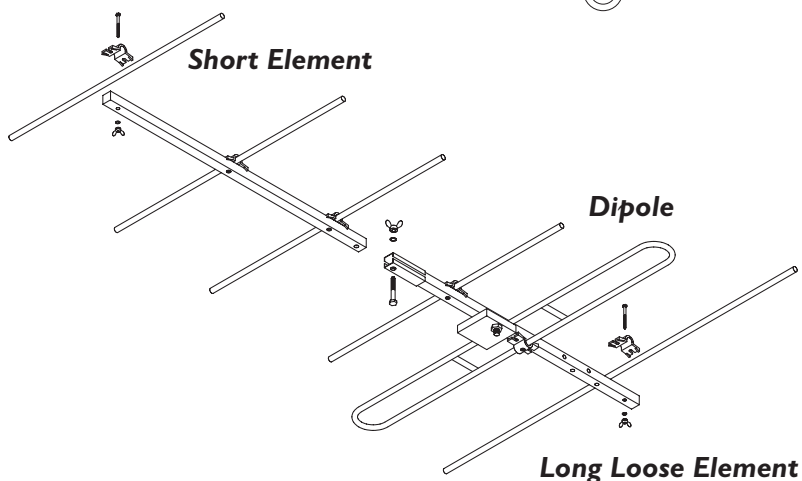

**Step 3**

Slide the booms of the two antenna sections together using the attachment bracket, screw and wing nut provided. See diagram.

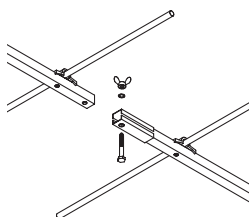

**Step 4**

Strip coax cable as shown in diagram.

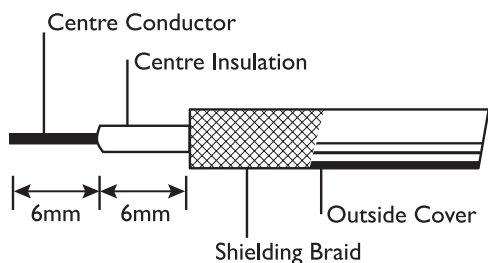

**Step 5**

Cut the rubber boot seal provided and slide onto stripped cable as in diagram.

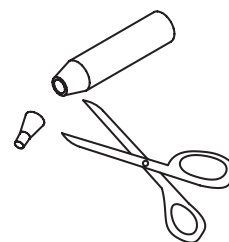

### Step 6

Select connector provided.

(Suitable for RG6 or semi airspaced cable)

Place "F" connector on back to front and twist to ensure that all braid is flat. See diagram.

(For other cable types you will need to purchase the corresponding connector)

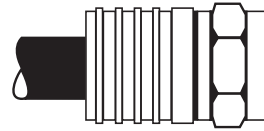

### Step 7

Then insert cable into rear of connector and twist connector clockwise until dielectric is flush with the bottom nut as illustrated. Ensure that 2-3mm of centre core conductor protrudes past the nut and that the braid makes contact with the inner body of the connector.

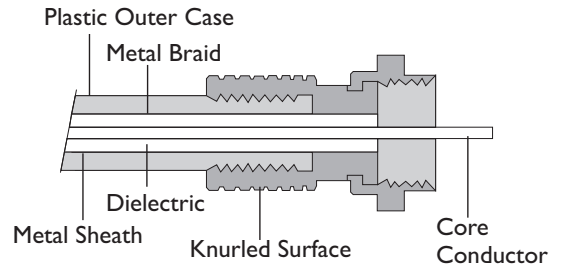

### Step 8

Assemble "U" bolt into boom.

See diagram. NB In vertical polarized areas, you can use a 11MM-SMI-15 mount (15" vertical stand off boom sold separately).

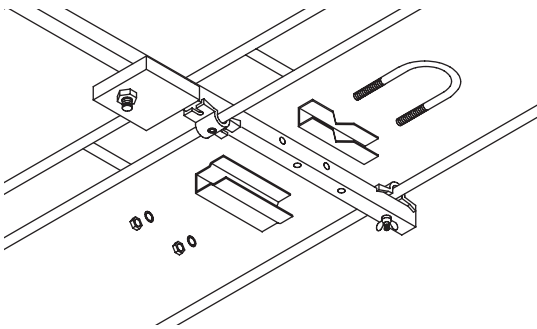

### Step 9

Connect cable to 'F' connector on balun, tighten with fingers.

**WARNING OVER TIGHTENING OF CONNECTOR MAY DAMAGE CIRCUIT BOARD.**

Slide boot seal over connector for protection.

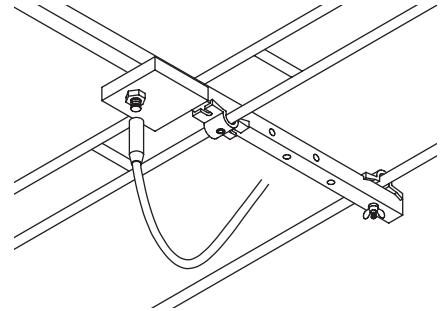

### Step 10

Attach antenna to mast and point to transmitter. The shortest elements point to the transmitter.

Rotate antenna to achieve best results. Attach cable to mast with UV grade insulation tape or UV grade cable ties to support cable weight and avoid damage to connection from wind whipping cable from side to side.

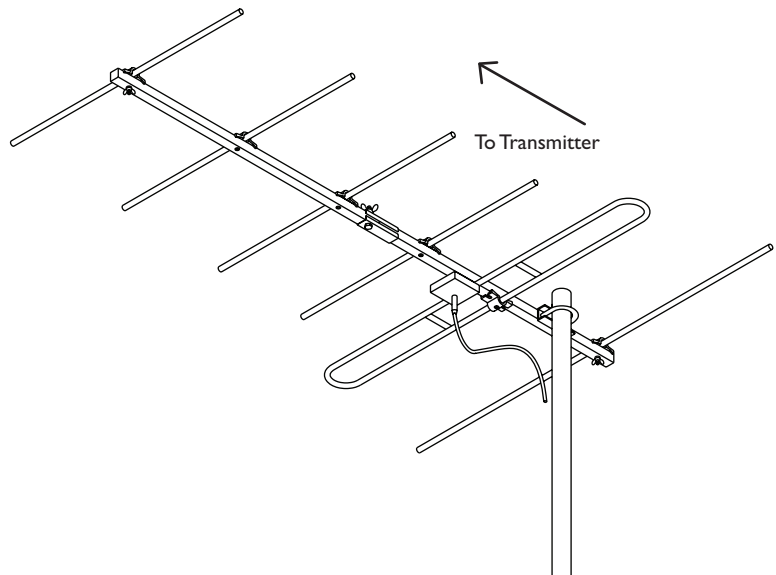

### Step 9

For digital compatibility terminate cable into suitable "F" type splitters such as 07MM-GM02 or 07MM-GM04 or "F" outlet plates such as 05MM-WP01 or 05MM-WP11.

**NB** RG6 cable with aluminium foil and aluminium braid is ideal for digital reception.

**N.B.2** If close to transmitter use DA-FLY2M Quad shield flylead to avoid interference.