

## Minitube Plastic Series – MTP306

Location

Project

Designation

Notes



### Features

The Minitube Plastic Series of duct mounted axial fans is suitable for applications ranging from domestic to commercial ventilation.

#### Construction

All models have a powder-coated galvanised steel fan impeller.  
Casing: - 'MTP' range: ABS plastic casing.

#### Motors

Type - external rotor, squirrel cage induction motor.  
Electricity supply - 220-240V, single-phase, 50/60Hz.  
Bearings sealed-for-life, ball.  
Speed-controllable.  
Motor protection IP44.  
If flameproof motors for hazardous locations are required, refer to Compact Miniduct Series.

#### Internal Thermal Protection

Manual reset type fitted as standard on models 202 and above.  
Model 132 is protected by an internal fuse.

#### Testing

Air flow tests to ISO5801:2004  
Noise tests to BS848:Part 2, 1985

#### Special Features

Can be mounted at any angle.  
Tapered ends on 'MTP' range allows standard sized duct to slide on easily

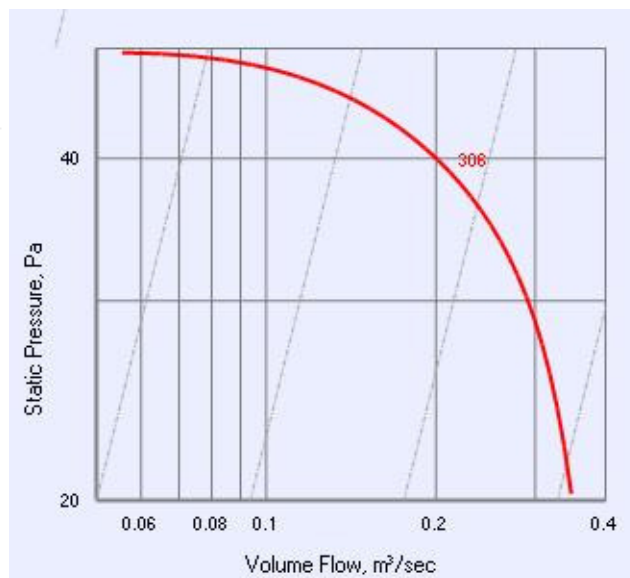

### Technical Data - MTP306

Speed [rps]	Avg. dBA @ 3m	kWatts (Input)	Amps	Max. °C	Approx. Weight [kg]
22	37	0.092	0.42	50	4.8

### Sound Data

Type	63	125	250	500	1K	2K	4K	8K
Inlet	53	57	55	53	54	52	44	

## Minitube Plastic Series – MTP306

### Suggested Specification

The fans shall be of the Minitube Series designed and manufactured by Fantech Pty. Ltd. The axial impellers shall be direct driven by speed-controllable external rotor motors with integral thermal protection.

The casings shall be manufactured from ABS plastic with mounting brackets as an integral component. The impellers shall be manufactured from galvanised steel with a powder-coat finish.

All models shall be fully tested to ISO5801:2004 for air flow and BS848:Part 2, 1985 for noise in fully certified laboratories.

### Dimensions

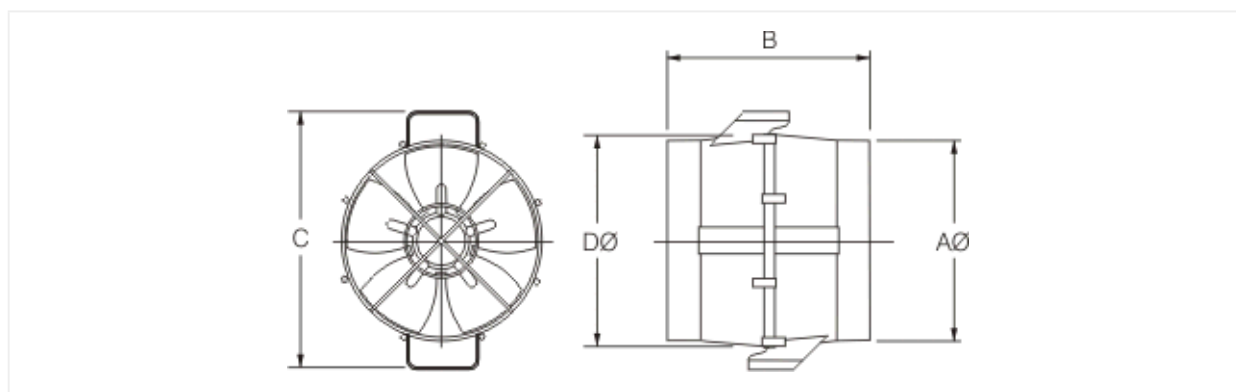

A	B	C	D
297	250	370	315

All dimensions in mm, unless otherwise stated

### Contacts



#### OFFICES & AGENTS

##### Victoria

Fantech Pty. Ltd.  
Tel:+61 (03) 9554-7845

##### New South Wales

Fantech Pty. Ltd.  
Tel:+61 (02) 8811-0400

##### Uniair Distributors Pty. Ltd.

Tel:+61 (02) 4961-6088  
**Refrigeration and Air Supplies**  
Tel:+61 (02) 4226-5133  
**Fantech Pty. Ltd.**  
Tel:+61 (02) 6025-1866

##### South Australia

**Fantech Pty. Ltd.**  
Tel:+61 (08) 8294-0530

##### Queensland

**Air Design Pty. Ltd.**  
Tel:+61 (07) 3299-9888  
**Capricorn Air Conditioning**  
Tel:+61 (07) 4775-5222

##### Northern Territory

**Fantech Pty. Ltd.**  
Tel:+61 (08 ) 8947-0447

##### Western Australia

**Systemaire Pty. Ltd.**  
Tel:+61 (08) 9209-4999

##### Tasmania

**Major Air Pty. Ltd.**  
Hobart  
Tel:+61 (03) 6344-6888  
Tel:+61 (03) 62736455

##### ACT

**Idealair Group Pty. Ltd.**  
Tel:+61 (02) 6280-5511

##### Auckland

**Fantech (NZ) Ltd.**  
Tel:+64 (09) 444-6266

##### Christchurch

**Fantech (NZ) Ltd.**  
Tel:+64 (03) 379-8622

##### Wellington

**Fantech (NZ) Ltd.**  
Tel:+64 (04) 566-0532