

IQ8X Microinverters

The smart grid-ready IQX Microinverters^{1,2} are designed to match the latest generation high-output PV modules. These microinverters have the best in class energy production and highest reliability standards in the industry, and with rapid shutdown functionality, they meet the highest safety standards.

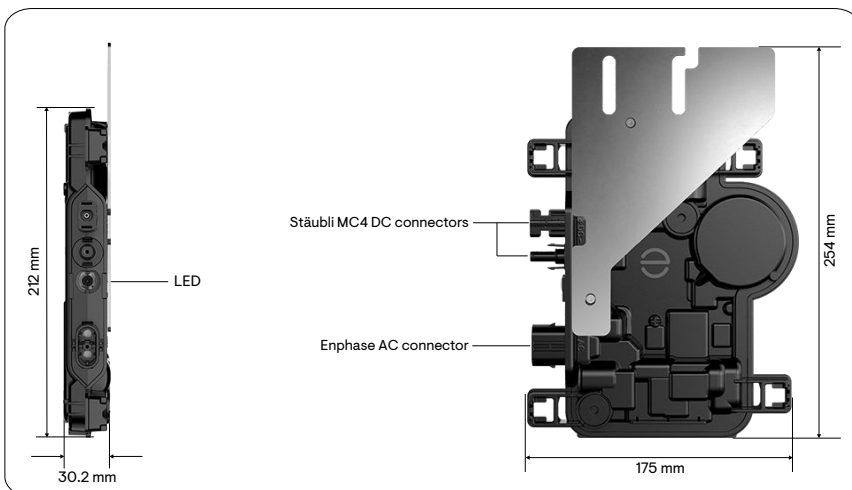

Key specifications	IQ8X-80-M-INT
Maximum AC output power	384 W
Nominal grid voltage	230 V
Nominal frequency	50 Hz
European weighted efficiency	96.7%
Minimum/Maximum input voltage	25/79.5 V
Minimum/Maximum MPP voltage	43/60 V
Maximum short-circuit DC input current	16 A
Ambient air temperature range	-40°C to 65°C (-40°F to 149°F)



Simple

- Compatible with existing IQ7 systems. Seamlessly expand your solar capacity as your energy requirements increase¹
- Lightweight and compact with integrated Stäubli MC4 connectors for easy installation
- Faster installation with simple AC cabling
- Faster firmware upgrades enabled by the new integrated circuit technology

Reliable

- More than one million cumulative hours of testing
- Patented Burst Mode technology provides increased energy production
- Low-voltage DC and rapid shutdown for the ultimate fire safety
- Industry-leading warranty of up to 25 years³

Compatible

- Supports higher-voltage, typically 80-half-cell, 88-half-cell, 96-cell, PV modules

¹ For details, see the "Compatibility with IQ7 Series Microinverters" section.
² A 25-year limited warranty is valid, provided an internet-connected IQ Gateway is installed.
³ A 25-year warranty is valid, provided an internet-connected IQ Gateway is installed.

Input data (DC)	Parameters	Units	IQ8X-80-M-INT
Typical module compatibility	—	—	80-half-cell,88-half-cell, 96-cell No enforced DC/AC ratio and maximum input power. Modules can be paired as long as the maximum input voltage is not exceeded and the maximum input current of the inverter is respected at the lowest and highest temperatures. See the compatibility calculator at https://enphase.com/en-au/installers/microinverters/calculator .
Minimum/Maximum input voltage	U_{dcmin}/U_{dcmax}	V	25/79.5
Startup input voltage	$U_{dcstart}$	V	30
Rated input voltage	$U_{dc,r}$	V	51.5
Minimum/Maximum MPP voltage	U_{mppmin}/U_{mppmax}	V	43/60
Minimum/Maximum operating voltage	U_{opmin}/U_{opmax}	V	25/79.5
Maximum input current	I_{dcmax}	A	10
Maximum short-circuit DC input current	I_{scmax}	A	16 Maximum short circuit current for modules (I_{sc}) allowed to be paired with IQ8X Microinverters: 13 A (calculated with 1.25 safety factor as per IEC 62548).
Maximum input power ⁴	P_{dcmax}	W	505
Output data (AC)	Parameters	Units	IQ8X-80-M-INT
Maximum apparent power	$S_{ac,max}$	VA	384
Rated apparent power	$P_{ac,r}$	W	380
Nominal grid voltage	U_{acnom}	V	230
Minimum/Maximum grid voltage	U_{acmin}/U_{acmax}	V	184/276
Rated/Maximum output current	$I_{ac,max}$	A	1.65/1.67
Nominal frequency	f_{nom}	Hz	50
Minimum/Maximum frequency	f_{min}/f_{max}	Hz	45/55
Maximum units per single-phase 20 A circuit Maximum units per multi-phase 25 A circuit	—	—	10 (L+N) single-phase 36 (3L+N) multi-phase For IQ Cable with 2.5 mm ² stranded conductors and using a 1.20 safety factor. The safety factors applied may vary based on local regulations or best practices, as well as upon the characteristics of the OCPD selected.
Recommended maximum units per single/multi-phase IQ Cable section to reduce voltage rise in IQ Cable	—	—	8 (L+N) single-phase 18 (3L+N) multi-phase It is recommended that the IQ Cable be center-fed within microinverter branch circuits to minimize the voltage rise. These design limits should ensure voltage rise and line conductor resistance on the IQ Cable are maintained within acceptable limits. In locations with a risk of high grid voltage at the point of connection, it may be necessary to decrease the maximum number of microinverters on the IQ Cable section by as much as 50%.

⁴ Pairing PV modules with wattage above the limit may result in additional clipping losses. See the compatibility calculator at <https://enphase.com/en-au/installers/microinverters/calculator>.

Output data (AC)	Parameters	Units	IO8X-80-M-INT
Protective class (all ports)	—	—	II
Total harmonic distortion	—	%	<5
Power factor setting	—	—	1.0
Power factor range	cos phi	—	0.8 leading ... 0.8 lagging
Inverter maximum efficiency	η_{\max}	%	97.5
European weighted efficiency	η_{EU}	%	96.7
Inverter topology	—	—	Isolated (HF transformer)
Night-time power loss	—	mW	50
Mechanical data		Units	IO8X-80-M-INT
Ambient air temperature range		°C (°F)	-40 to 65 (-40 to 149)
Relative humidity range		%	4 to 100 (condensing)
Overvoltage class AC port		—	III
Number of input DC connectors (pairs) per single MPP tracker		—	1
AC connector type		—	IQ Cabling (refer to the IQ Cable and accessories data sheet)
DC connector type		—	Stäubli MC4
The decisive voltage class (DVC)		—	AC: DVC C DC: DVC B
Dimensions (H × W × D)		mm (in)	212 (8.3) × 175 (6.9) × 30.2 (1.2) (without mounting brackets)
Weight (with mounting plate)		kg (lb)	1.1 (2.4)
Cooling		—	Natural convection – no fans
Enclosure		—	Class II double-insulated, corrosion-resistant polymeric enclosure
IP rating		—	Outdoor- IP67
Altitude		m	<2600
Calorific value		MJ/unit	37.5
Standards			IO8X-80-M-INT
Grid compliance			AS/NZS 4777.2:2020 + A2
Safety			EN IEC 62109-1, EN IEC 62109-2
EMC			EN IEC 61000-3-2, 61000-3-3, 61000-6-2, 61000-6-3, EN IEC 50065-1, 50065-2-2, EN 55011 ⁵
Product labelling			CE, RCM
Advanced grid functions ⁶			Power export limiting (PEL), phase imbalance management (PIM), loss of phase detection (LOP), power factor control Q (U), cos (phi) (P)
Microinverter communication			Powerline communication (PLC) 110–120 kHz (Class B), narrowband 200 Hz

⁵ At STC within the MPP range.

⁶ Some of these functions require IQ Gateway Metered with current transformers and/or IQ Relay installed.

Compatibility with IQ7 Series Microinverters

- IQ8 Series Microinverters can be added to existing IQ7 systems on the same IQ Gateway/IQ Combiner/IQ System Controller only in the following configurations: (i) Solar Only or (ii) Solar + Battery (IQ Battery 5P) grid-tied or Solar + Battery (IQ Battery 5P) with backup with IQ System Controller 3 INT.
- IQ7 Series Microinverters cannot be added to a site with existing IQ8 Series Microinverters on the same gateway.
- A mixed system with both IQ7 and IQ8 Series Microinverters does not support the IQ8-specific Sunlight Jump Start feature.
- The peak power output of the IQ7, IQ8 Microinverter arrays must not exceed 150% of the IQ Battery's rated power output. If the microinverter array exceeds this ratio, PV shedding must be implemented to shed excess PV when the system transitions to off-grid mode.

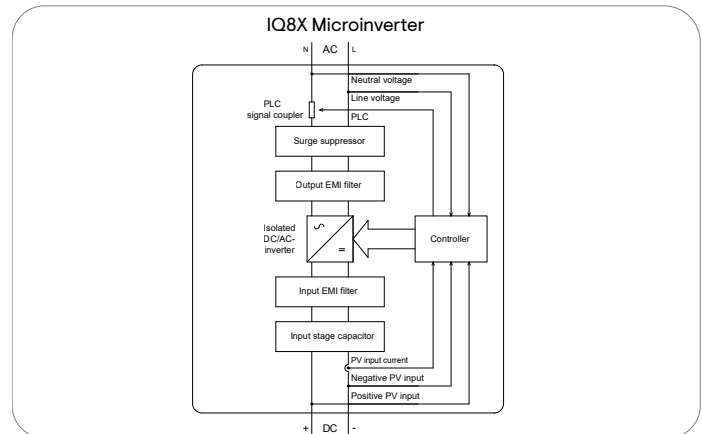
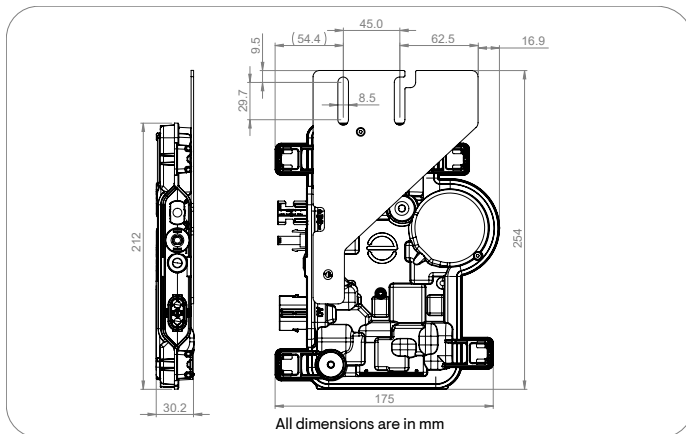
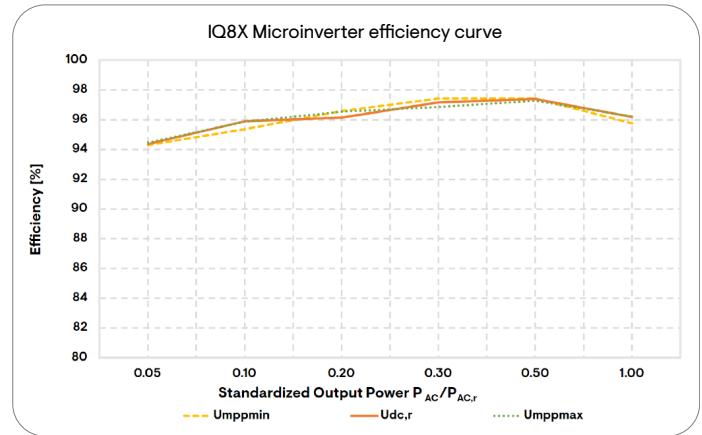
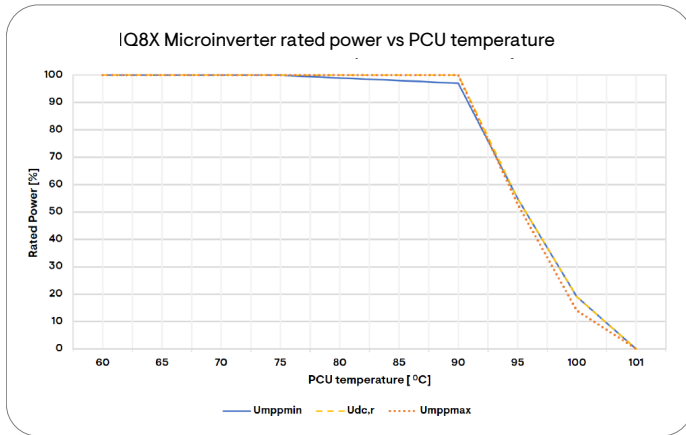

Assembled in India, U.S., or China

Manufacturer: Enphase Energy Inc. 47281 Bayside Pkwy, Fremont, CA 94538, United States of America, Tel: +1 (707) 763-4784

Importer: Enphase Energy NL B.V., Het Zuiderkruis 65, 5215MV, 's-Hertogenbosch, The Netherlands, Tel: +31 73 3035859

Components of the Enphase Energy System



IQ Gateway

The IQ Gateway is the platform for energy management and integrates with IQ Microinverters and IQ Batteries to provide complete control and insights into the Enphase Energy System.

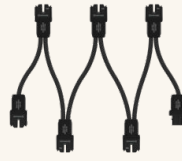

IQ Cable

Install microinverters quickly and safely with IQ Cabling. With multi-phase IQ Cabling, the installed capacity is automatically distributed evenly across all three phases.



IQ Relay single-phase and multi-phase

Production and storage circuit, integrated neutral sensing protection device with PLC-phase coupler (multi-phase) and DC current injection monitoring.



IQ Battery 5P

Part of the Enphase Energy System, the IQ Battery 5P integrates with the IQ8 Series Microinverters, IQ System Controller 3 INT, and the Enphase App monitoring and analysis software.

Revision history

Revision	Date	Description
DSH-00240-8.0	August 2025	Updated information on backward compatibility for IQ8/IQ7 Series Microinverters.
DSH-00240-7.0	July 2025	Updated minimum/maximum frequency value.
DSH-00240-6.0	July 2025	Internal updates.
DSH-00240-5.0	April 2025	Updated information on backward compatibility with IQ7 Series Microinverters.
DSH-00240-4.0	August 2024	Updated the warranty information.
DSH-00240-3.0	June 2024	Updated the IQ8X Microinverter figure and removed the “SCHEDULED TO RELEASE IN Q2 2024” tag.
DSH-00240-2.0	February 2024	Initial release.
DSH-00240-1.0	March 2024	Preliminary release.