

TECHNICAL DATA – GREEN-LITE SLIM 40

PRODUCT CODE	SLIMGL40
VOLTAGE	220-240V 50 Hz
TUBE TYPE	T5 40 Watt Tri-Phosphor Circular Fluorescent (FC40WT5) 5000°K
ELECTRONIC BALLAST	EI-Electric FC-40W
WIRING	All wiring PVC single core (V 105°c)
TERMINAL BLOCK	'Quick Connect' terminal block 3 pole including earth
DIFFUSER	Plexiglas® Opal Cast Acrylic
BACK PLATE	Aluminium
CLIPS	Plated Spring Steel for positive attachment of diffuser & tube
LAMP HOLDER	UV stabilized 2GX13

VARIATIONS / OPTIONS

ELECTRONIC BALLAST	Vossloh ELXc 142.872 or Tridonic PC 1/26/32/42 TC PRO
TUBE TYPE	FC40WT5 Green-Lite 3000°K Osram 3000°K/4000°K
DIMMABLE BALLAST	Tridonic – PCA 1/40 T5c ECO
DALI DIMMABLE	Tridonic – PCA 1/40 T5c EXCEL One4all
DIFFUSER	Matt Finish
IPx4 RATING	For use under eaves, bathrooms or walkways

DIMENSIONS

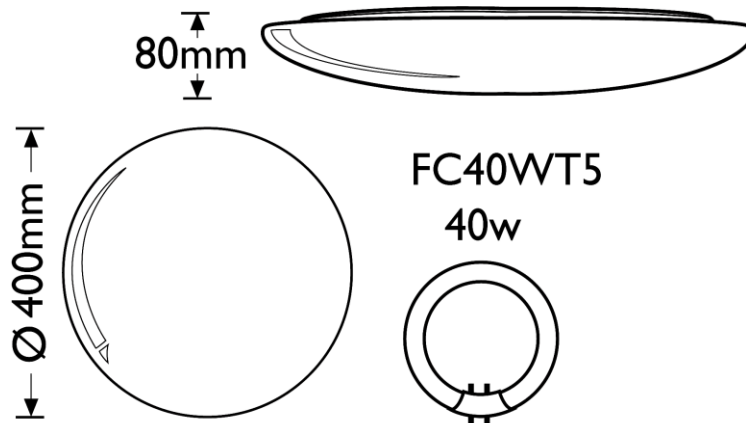

INSTALLATION

Installation is to be performed by a Licensed Electrical Contractor.

CARE OF DIFFUSER

To clean use warm soapy water and cloth then chamois dry.

To remove scratches on outside surface use brasso™ or a fine abrasive such as toothpaste.

REPLACEMENT PARTS

Tube	FC40W available in Tri-Phosphor
	3000°K Twi-Lite Green-Lite / Osram
	5000°K Hi-Fidelity Green-Lite/Osram
	4000°K Cool White Osram

Diffuser	Product Code: DFSLIM40
----------	------------------------

brasso™ is the registered trademark of Reckitt & Colman Products Ltd.