



PRESTON 48in HUGGER DC CEILING FAN



- 48**
INCH
1220mm
- 30W**
DC
MOTOR
- 20°**
BLADE
PITCH
- 10100**
m³/hr
AIRFLOW
- ABS**
BLADES
- 6YR**
WARRANTY

Remote control
Included

A low-profile design, with clean, modern look makes the Preston an ideal ceiling fan for homes & apartments with lower ceiling heights. Featuring a powerful DC motor paired with an aerodynamic blade design, this hugger style fan can provide comfortable and effective airflow all year round.

- High strength, corrosion proof and easy clean ABS blades
- The Windbreeze mode varies the fan speed to simulate a natural breeze effect.
- 6 speed remote control with timer included.
- Reversible All-Seasons technology for use all year round
- Powerful 30W DC motor
- Uses Brilliant's Quick Connect Plug System to reduce install time

APPLICATIONS

- Ideal for lower ceilings
- Bedrooms, lounge and family rooms
- Indoors or enclosed alfresco areas not exposed to the weather



MATT WHITE



MATT BLACK



PRESTON 48in HUGGER DC CEILING FAN

TECHNICAL SPECIFICATIONS

Size	48 inch (1220mm)
Motor Type	DC (Direct Current)
Operating Voltage	220-240V / 50Hz
Motor Wattage	30W
Construction	Metal body and canopy
Blade Material	Moulded ABS (x3)
Ceiling install	Flat mount only
Blade Pitch	20 degrees
Ceiling Rake	Flat mount only
Other models available	22089: 48-inch with light
Control	Remote 6-speed with reverse and windbreeze functions
Warranty	3 year in-home plus 3 year replacement (6-Year) <i>*Limited warranty for wall controller, remote controller and light. Refer to warranty card inside the box for more details.</i>



INSTALLATION

Must be installed by a licensed electrician

AIR MOVEMENT

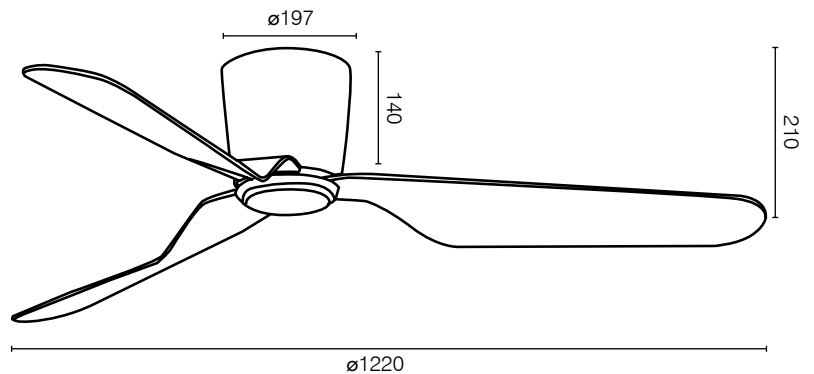
SPEED	1	2	3	4	5	6
RPM	100	120	140	160	180	200
Power	4W	6W	9W	12W	19W	30W
Airflow	4200m ³ /h	5300m ³ /h	6400m ³ /h	7500m ³ /h	8600m ³ /h	10100m ³ /h



	MODEL	COLOUR	DESCRIPTION	BOX SIZE	GROSS WEIGHT	BOX QTY	BARCODE/TUN
RETAIL BOX	22087/05	Matt White	Preston-48 Hugger Fan	W717 x H305 x D282 mm	4.8 kg	1 pc	 >
RETAIL BOX	22087/06	Matt Black	Preston-48 Hugger Fan	W717 x H305 x D282 mm	4.8 kg	1 pc	 >