

## AT9029 TRI

10W LED COB Adjustable & Fixed head with dimmable driver

- Avail. In small, fixed & adjustable versions
- Supplied with dimmable LED driver
- Low-glare UGR 19 rating
- Ideal for commercial, retail, showroom and decorative



### ORDERING INFORMATION

<b>Order code</b>	11674
<b>Description</b>	10W LED COB Adjustable downlight w/Dimm Driver - 50Deg beam - 90mm cut-out - White - TRI CCT
<b>Driver Type</b>	Dimmable ( Phase cut)
<b>Item Code</b>	AT9029/ADJ/WH/TRI

### EFFICIENCIES

**Total System Efficiency** 98 lm/W

The performance of each component of a luminaire is demonstrated through its efficiencies, which together determine the total system efficiency of the product. The output of the LED chip is first multiplied by the optical and thermal efficiencies to calculate the Luminaire efficiency. However, this calculation does not consider the driver efficiency. To determine the overall efficiency of the system, the Luminaire efficiency must be multiplied by the driver efficiency, which accounts for all losses in the system.

### MECHANICAL

<b>Adjustability</b>	Adjustable
<b>Body Material</b>	Aluminium
<b>Diffuser Material</b>	Glass
<b>Product Finish</b>	Powdercoated
<b>Fitting Colour</b>	White
<b>IC Rating</b>	IC-4

IC-4 rating has been conducted at the products maximum working Temperature Range (C) in line with Australian standards. This provides the required safety when covered with insulation and used in Australian Environments.

<b>Installation Type</b>	Recessed
--------------------------	----------

**IP Rating** IP54 Front Face Only

### ELECTRICAL

<b>Electrical Rating</b>	Class II
<b>Input Frequency</b>	50 Hz
<b>Input voltage</b>	230Vac
In Australia the Input voltage is defined as 230Vac -6%/+10%. This effectively means that the voltage range of these products are 216Vac - 253Vac or 240V +6%	
<b>Switch Type</b>	Inline
<b>System Max Wattage</b>	10 W
<b>Working Temp Range</b>	-20 to 40 °C

### LAMP

<b>Beam Angle</b>	50 °
<b>CCT Configuration</b>	TRI-CCT
<b>Colour Rendering Index (CRI)</b>	>80
<b>Lamp/LED Current</b>	230 mA
<b>Lamp/LED voltage</b>	36 V
<b>UGR</b>	<16

### LED LIFETIME

<b>Ambient Temp (°C)</b>	25 °C	40 °C
<b>L80B10</b>	>55000 hrs	>55000 hrs

This rating defines the performance of the led within its lifetime. L relates to lumen depreciation, where the proceeding number gives the resultant lumen output at the end of it reported lifetime. L70, would mean 30% lumen depreciation which means 70% of its initial output and is tested accordingly to TM-21. The B part refers to failures, which can be define as the percentage of LEDs which fall below the L value in the projected lifetime. A value of B10 refers to 10% failure and a value of B50 refers to 50% failure. After the defined lifetime, the system will reach the defined

lumen depreciation and the average led failures is defined by the B rating. The B rating is defined in and tested to IEC62717.

**TM-21 Test Hours** 10000 hrs

## COLOUR TEMPERATURE

Warm White (3000 K)	890 lm
Cool White (4000 K)	980 lm
DayLight (5000 K)	930 lm

## DRIVER

<b>Dimmable</b>	Yes
<b>Driver Included</b>	Yes
<b>Integrated Driver</b>	No
<b>Driver Type</b>	Dimmable ( Phase cut)
<b>Wiring Type</b>	Re-wireable Flex & Plug (2 pin)

## COMPLIANCE

**Daily Use** 12 hrs

The Daily Use is the recommended time required to meet the product's design life. Installations can exceed this time, however the product design life will be reduced proportionally.

**Standards** AS/NZS 60598.1  
AS/NZS 60598.2.2  
AS/NZS 61347.1  
AS/NZS 61347.2.13  
AS CISPR 15

## WARRANTY

**Domestic Use Warranty** 3 RTB (Total 3 Years)

**VIP Warranty** 2 Onsite, 3 RTB (Total 5 Years)

VIP warranty is available to registered users and is subjected to additional terms and conditions.

## DIMENSIONS

<b>Cutout</b>	90 mm
<b>Product Diameter</b>	95 mm
<b>Product Height</b>	95 mm

## LINE DRAWINGS

### AT9029/ADJ/TRI

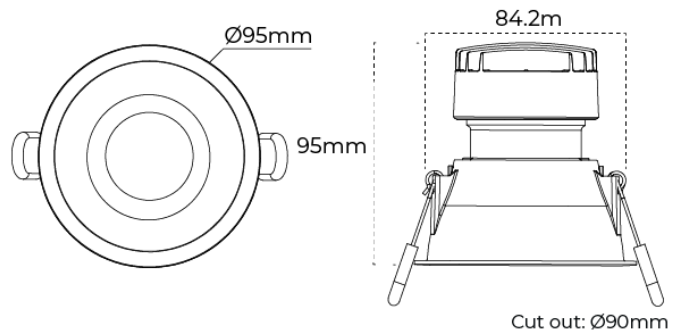

## ACCESSORIES

<b>Order code</b>	10121
<b>Description</b>	140mm Downlight Extension Plate - White
<b>Item Code</b>	AT9018/WH
<b>Order code</b>	10130
<b>Description</b>	170mm Downlight Extension Plate - White
<b>Item Code</b>	AT9019/WH