

PC T8 PRO 18–70 W 220–240 V 50/60/0 Hz

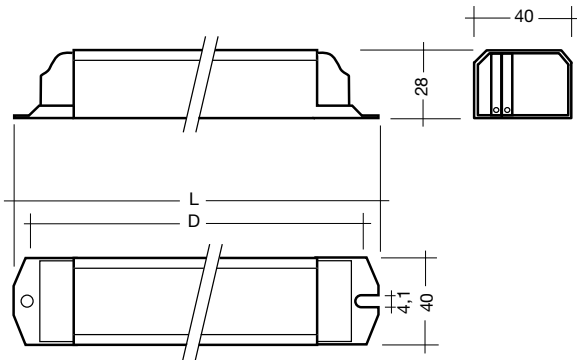

- defined warm start within 1.5 s
- constant light output independent of fluctuations in mains voltage
- Average service life = 50,000 h (at t_a max. with a failure rate ≤ 0.2 % per 1000 operating hours)
- AC voltage range 198–264 V
- DC voltage range 176–280 V, for ignition input voltage ≥ 198 V
- power factor > 0.96
- overvoltage protection 320 V AC, 1 h
- overvoltage indication starting at input voltage 267–306 V AC
- undervoltage protection (shut down) below 150 V AC / 176 V DC
- operating frequency ≥ 40 kHz

- suitable for automatic and manual wiring with insulation displacement connector (IDC)
- wide operating temperature range from -25 °C up to $+60$ °C (t_a values see table)
- Energy Efficiency Index CELMA EEI = A2 (PC 3/36 T8 PRO: EEI = A3)
- suitable for use in emergency lighting installations in accordance with VDE 0108
- safe switch off of defective lamps
- automatic re-start after lamp change
- for luminaires with ∇ or ∇ and ∇ in acc. with EN 60598/VDE 0710 and VDE 0711
- suitable for luminaires with protection class SK I and SK II
- Ingress protection IP 20
- thermal protection according to EN 61347-2-3 C5e (∇ for 2x58 W)

Packaging L=234:
box of 10
63 carton/pallet
630 pieces/pallet

Packaging L=360:
box of 10
42 carton/pallet
420 pieces/pallet

Certified:
EN 55015
EN 55022
EN 61347-2-4
EN 60925
EN 61347-2-3
EN 60929
EN 61000-3-2
EN 61547
in accordance with VDE 0108
IEC 68-2-64 Fh
IEC 68-2-29 Eb
IEC 68-2-30

Lamp		Ballast													
watt- age W	length mm	type	article number	length mm	fixing centres D mm	weight kg	lamp power W	circuit power W ①	Celma class EEI	current at 50Hz 220V A 240V A		λ at 50Hz 220V 240V		tc point °C	temperature range t_a °C
1x18	590	PC 1/18 T8 PRO 220–240 V 50/60/0 Hz ②	22176005	234	220	0.28	16	18.5	A2	0.09	0.08	0.97	0.97	70	-25 → +55
2x18	590	PC 2/18 T8 PRO 220–240 V 50/60/0 Hz ②	22176008	234	220	0.28	32	36.5	A2	0.17	0.16	0.97	0.97	75	-25 → +55
3x18	590	PC 3/18 T8 PRO 220–240 V 50/60/0 Hz	22088146	234	220	0.28	48	54.5	A2	0.26	0.24	0.97	0.97	75	-25 → +50
4x18	590	PC 4/18 T8 PRO 220–240 V 50/60/0 Hz	22088152	234	220	0.28	64	73.0	A2	0.34	0.31	0.97	0.97	75	-25 → +50
1x30	900	PC 1/30 T8 PRO 220–240 V 50/60/0 Hz	22176077	234	220	0.28	24	28.0	A2	0.13	0.12	0.97	0.96	75	-25 → +60
2x30	900	PC 2/30 T8 PRO 220–240 V 50/60/0 Hz	22176078	234	220	0.28	50	56.0	A2	0.26	0.24	0.97	0.96	75	-25 → +60
1x36	1200	PC 1/36 T8 PRO 220–240 V 50/60/0 Hz ②	22176006	234	220	0.28	32	35.5	A2	0.17	0.15	0.97	0.97	75	-25 → +55
2x36	1200	PC 2/36 T8 PRO 220–240 V 50/60/0 Hz ②	22176009	234	220	0.28	64	72.0	A2	0.34	0.31	0.97	0.97	75	-25 → +50
3x36	1200	PC 3/36 T8 PRO 220–240 V 50/60/0 Hz	22176075	360	350	0.34	96	110.0	A3	0.51	0.47	0.99	0.98	70	-25 → +50
1x58	1500	PC 1/58 T8 PRO 220–240 V 50/60/0 Hz ②	22176007	234	220	0.28	50	54.5	A2	0.26	0.23	0.97	0.97	75	-25 → +50
2x58	1500	PC 2/58 T8 PRO 220–240 V 50/60/0 Hz ②	22176010	234	220	0.28	100	107.0	A2	0.50	0.45	0.98	0.98	80	-25 → +50
1x70	1800	PC 1/70 T8 PRO 220–240 V 50/60/0 Hz	22088357	234	220	0.28	60	68.0	A2	0.32	0.29	0.97	0.97	75	-25 → +50
2x70	1800	PC 2/70 T8 PRO 220–240 V 50/60/0 Hz	22088341	360	350	0.36	120	130.0	A2	0.60	0.55	0.98	0.98	65	-25 → +50

① measured according to EN 50294

② Types will be replaced by the new **xtec** generation until end of 2007.

Lamp starting characteristics

Warm start

Starting time 1.5 secs with AC and DC operation

Cathode heating will be reduced after preheat time

AC operation

Mains voltage:

220–240 V 50/60 Hz

198–264 V 50/60 Hz including safety

tolerance ($\pm 10\%$)

202–254 V 50/60 Hz including performance

tolerance (+6 % / -8 %)

DC operation

220–240 V 0 Hz

198–280 V 0 Hz certain lamp start

176–280 V 0 Hz operating range

Light output level in DC operation: 100 %

Emergency lighting

Use in emergency lighting installations according to VDE 0108 or for emergency luminaires according to EN 61347-2-3 appendix J.

Instant start after mains interruption < 0.5 s



Intelligent Voltage Guard

Intelligent Voltage Guard is the name of the new electronic monitor from TridonicAtco. This innovative feature of the PC PRO family of control gear from TridonicAtco immediately shows if the mains voltage rises above or falls below certain thresholds. Measures can then be taken quickly to prevent damage to the control gear.

- If the mains voltage rises above approx. 305 V (voltage depends on the ballast type), the lamp starts flashing on and off.
- This signal “demands” disconnection of the power supply to the lighting system.
- If the mains voltage falls below 150 V the control gear automatically disconnects the lamp circuit to protect the control gear from being irreparably damaged.



Smart Heating

Innovative heating circuit. Reduced filament heating after lamp has struck.

Mains currents in DC operation

Type	lamp type	wattage W	Mains current at $U_n = 220$ VDC	Mains current at $U_n = 240$ VDC
PC 1/18 T8 PRO	T8	1x18	0.09 A	0.08 A
PC 2/18 T8 PRO	T8	2x18	0.17 A	0.16 A
PC 3/18 T8 PRO	T8	3x18	0.27 A	0.25 A
PC 4/18 T8 PRO	T8	4x18	0.36 A	0.33 A
PC 1/30 T8 PRO	T8	1x30	0.16 A	0.15 A
PC 2/30 T8 PRO	T8	2x30	0.27 A	0.25 A
PC 1/36 T8 PRO	T8	1x36	0.16 A	0.15 A
PC 2/36 T8 PRO	T8	2x36	0.33 A	0.30 A
PC 3/36 T8 PRO	T8	3x36	0.50 A	0.46 A
PC 1/58 T8 PRO	T8	1x58	0.25 A	0.23 A
PC 2/58 T8 PRO	T8	2x58	0.49 A	0.45 A
PC 1/70 T8 PRO	T8	1x70	0.33 A	0.30 A
PC 2/70 T8 PRO	T8	2x70	0.62 A	0.57 A

Harmonic distortion in the mains supply

Type	lamp type	wattage W	THD at 230 V / 50 Hz
PC 1/18 T8 PRO	T8	1x18	< 10 %
PC 2/18 T8 PRO	T8	2x18	< 10 %
PC 3/18 T8 PRO	T8	3x18	< 10 %
PC 4/18 T8 PRO	T8	4x18	< 10 %
PC 1/30 T8 PRO	T8	1x30	< 10 %
PC 2/30 T8 PRO	T8	2x30	< 10 %
PC 1/36 T8 PRO	T8	1x36	< 10 %
PC 2/36 T8 PRO	T8	2x36	< 10 %
PC 3/36 T8 PRO	T8	3x36	< 10 %
PC 1/58 T8 PRO	T8	1x58	< 10 %
PC 2/58 T8 PRO	T8	2x58	< 10 %
PC 1/70 T8 PRO	T8	1x70	< 10 %
PC 2/70 T8 PRO	T8	2x70	< 10 %

Working voltage

Type	lamp type	wattage W	U_{out}
PC 1/18 T8 PRO	T8	1x18	250 V
PC 2/18 T8 PRO	T8	2x18	250 V
PC 3/18 T8 PRO	T8	3x18	250 V
PC 4/18 T8 PRO	T8	4x18	250 V
PC 1/30 T8 PRO	T8	1x30	250 V
PC 2/30 T8 PRO	T8	2x30	250 V
PC 1/36 T8 PRO	T8	1x36	250 V
PC 2/36 T8 PRO	T8	2x36	250 V
PC 3/36 T8 PRO	T8	3x36	350 V
PC 1/58 T8 PRO	T8	1x58	250 V
PC 2/58 T8 PRO	T8	2x58	250 V
PC 1/70 T8 PRO	T8	1x70	250 V
PC 2/70 T8 PRO	T8	2x70	300 V

Ballast lumen factor

EN 60929 8.1

Type	lamp type	wattage W	AC/DC-BLF at $U = 198\text{--}254$ V, 25 °C
PC 1/18 T8 PRO	T8	1x18	1.00
PC 2/18 T8 PRO	T8	2x18	1.00
PC 3/18 T8 PRO	T8	3x18	1.00
PC 4/18 T8 PRO	T8	4x18	1.00
PC 1/30 T8 PRO	T8	1x30	1.00
PC 2/30 T8 PRO	T8	2x30	1.00
PC 1/36 T8 PRO	T8	1x36	1.00
PC 2/36 T8 PRO	T8	2x36	1.00
PC 3/36 T8 PRO	T8	3x36	1.00
PC 1/58 T8 PRO	T8	1x58	1.00
PC 2/58 T8 PRO	T8	2x58	1.00
PC 1/70 T8 PRO	T8	1x70	1.00
PC 2/70 T8 PRO	T8	2x70	1.00

All data are typical values

ASIC light management

ASIC (Application specific integrated circuit) is the very latest in lighting management design technology. The lamp friendly warm start is delivering maximum T8 lamp life and enables high switching frequency applications.

Energy class CELMA

PC T8 PRO ignition technology (smart heating) optimises lamp start and ensures no energy is wasted. After the lamp has struck the filament heating is reduced automatically to a defined minimum value. This reduction in filament heating, saves energy, yet maintains the proper operating conditions for the lamp. The lamp is always operated within specification.

Ambient Temperature

-25 °C to +50 °C resp. 55 °C resp. 60 °C

PC 1/xx T8 PRO, PC 2/xx T8 PRO

L = 234 mm

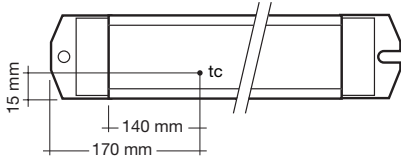

PC 3/18 T8 PRO, PC 4/18 T8 PRO

L = 234 mm

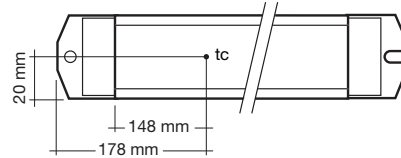

PC 3/36 T8 PRO

L = 360 mm

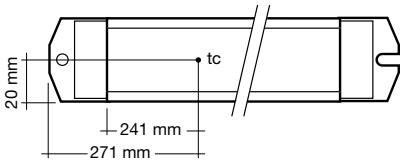

PC 2/70 T8 PRO

L = 360 mm

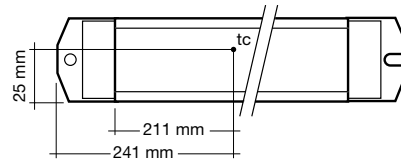

The nominal ta and tc point are related to the ballast life duration.

The relation of tc to ta temperature depends also on the luminaire design. If the measured tc temperature is approx. 5K below tc max., ta temperature should be checked and eventually critical components (e.g. ELCAP) measured. Detailed information on request.

PC T8 PRO is designed for an average service life of 50,000 hours under reference conditions and with a failure probability of less than 10 %. This corresponds to an average failure rate of 0.2 % for every 1,000 hours of operation.

Maximum loading of automatic circuit breakers

Automatic circuit	C10	C13	C16	C20	B10	B13	B16	B20
Installation Ø	1.5 mm ²	1.5 mm ²	1.5 mm ²	2.5 mm ²	1.5 mm ²	1.5 mm ²	1.5 mm ²	2.5 mm ²
PC 1/18 T8 PRO	44	62	74	104	22	31	37	52
PC 2/18 T8 PRO	36	50	60	72	18	25	30	36
PC 3/18 T8 PRO	40	60	80	92	20	30	40	46
PC 4/18 T8 PRO	30	40	52	64	15	20	26	32
PC 1/30 T8 PRO	40	52	60	72	19	26	30	36
PC 2/30 T8 PRO	22	30	38	42	11	15	19	21
PC 1/36 T8 PRO	38	52	60	72	19	26	30	36
PC 2/36 T8 PRO	24	32	38	44	12	16	19	22
PC 3/36 T8 PRO	18	24	32	40	9	12	16	20
PC 1/58 T8 PRO	36	50	60	70	18	25	30	35
PC 2/58 T8 PRO	16	22	26	30	8	11	13	15
PC 1/70 T8 PRO	20	26	34	42	10	13	17	21
PC 2/70 T8 PRO	10	14	16	20	5	7	8	10

Wiring advice

The lead length is dependant on the capacitance of the cable.

For safety reasons, the PC T8 PRO must only be earthed in the case of a safety class 1 luminaire.

Earthing is not required for the device to operate. Connection to earth reduces radio interference.

Ballast type	Terminal		Maximum capacitance allowed	
	Cold	Hot	Cold	Hot
PC 1/xx T8 PRO	11, 12	9, 10	200 pF	100 pF
PC 2/xx T8 PRO	11, 12, 13, 14	9, 10	200 pF	100 pF
PC 3/xx T8 PRO	11, 12, 13, 14, 15, 16	9, 10	200 pF	100 pF
PC 4/xx T8 PRO	5, 6, 11, 12, 13, 14, 15, 16	9, 10	200 pF	100 pF

With standard solid wire 0.5/0.75 mm² the capacitance of the lead is approx. 80 pF/m. This value is influenced by the way the wiring is made. In borderline cases the capacitance must be measured inside the luminaire.

Keep lamp wires short. Lamp connection with twin ballast should be made with symmetrical wiring. Hot leads and cold leads should be separated as much as possible.

Installation instructions

IDC interface

- solid wire with a cross section of 0.5 mm² according to the specification from WAGO

Horizontal interface

- solid wire with a cross section of 0.5–1.5 mm² according to the specification from WAGO
- strip 7.5–8.5 mm of insulation from the cables to ensure perfect operation of the screw terminals

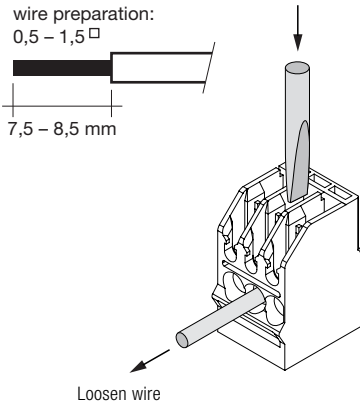

RFI

TridonicAtco ballasts are RFI protected in accordance with EN 55015 and EN 55022. To operate the luminaire correctly and to minimise RFI we recommend the following instructions:

- Connection to the lamps of the "hot leads" must be kept as short as possible (marked with *)
- Mains leads should be kept apart from lamp leads (ideally 5–10 cm distance)
- Do not run mains leads adjacent to the electronic ballast
- Twist the lamp leads

- Keep the distance of lamp leads from the metal work as large as possible
- Ballast must be earthed, either over the terminal or over the mounting screw of the ballast
- Mains wiring to be twisted when through wiring
- Keep the mains leads inside the luminaire as short as possible

Defective lamp

If a lamp is defective, the ballast switches off and goes into standby. There is an automatic restart once the lamp has been changed.

T8 lamp information

	wattage	length
	18 W	590 mm
	30 W	900 mm
	36 W	1200 mm
	58 W	1500 mm
	70 W	1800 mm

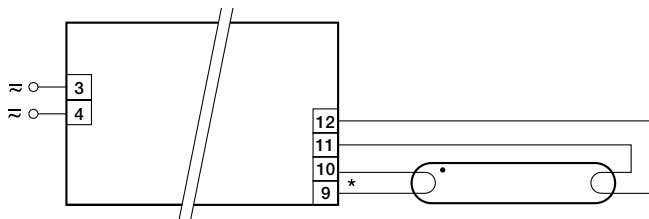

- * leads 9, 10 max. 1.0 m (< 100 pF)
- leads 11, 12 max. 2.0 m (< 200 pF)
- SK I - luminaires: earth of ballast housing required (according to IEC 598)
- SK II - luminaires: no earth required

PC 1x18–70 W T8 PRO

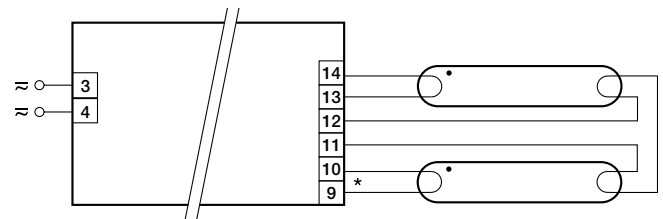

- * leads 9, 10 max. 1.0 m (< 100 pF)
- leads 11, 12, 13, 14 max. 2.0 m (< 200 pF)
- SK I - luminaires: earth of ballast housing required (according to IEC 598)
- SK II - luminaires: no earth required

PC 2x18–70 W T8 PRO

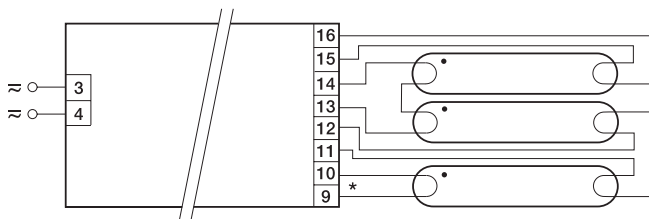

- * leads 9, 10 max. 1.0 m (< 100 pF)
- leads 11, 12, 13, 14, 15, 16 max. 2.0 m (< 200 pF)
- SK I - luminaires: earth via fixing of ballast housing with separated edge washer required (according to IEC 60598)
- SK II - luminaires: no earth required

PC 3x18 W T8 PRO, PC 3x36 W T8 PRO

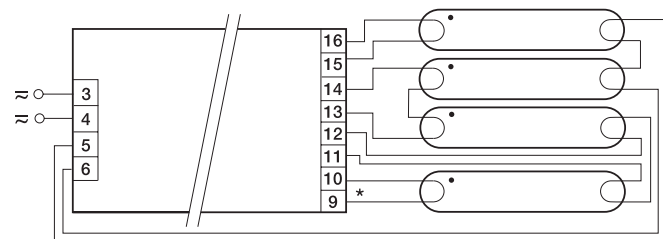

- * leads 9, 10 max. 1.0 m (< 100 pF)
- leads 5, 6, 11, 12, 13, 14, 15, 16 max. 2.0 m (< 200 pF)
- SK I - luminaires: earth via fixing of ballast housing with separated edge washer required (according to IEC 60598)
- SK II - luminaires: no earth required

PC 4x18 W T8 PRO