

Closed R80 Reflector Downlight

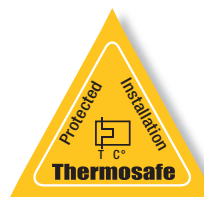

SD100
Economy 100w enclosed downlight for reflector lamps

- Thermal cut-off and auto reset function for protection against misuse and overloading.
- Lampholders can be prewired before assembly
- Designed for quicker installation
- Draft proof enclosed construction
- Suits a wide range of ceiling thicknesses
- Long life ceramic lamp holder
- **Acoustic rating**
STC55 ceiling = Min. spacing of 1.6M
STC57 and 58 = Min. spacing of 2.5M

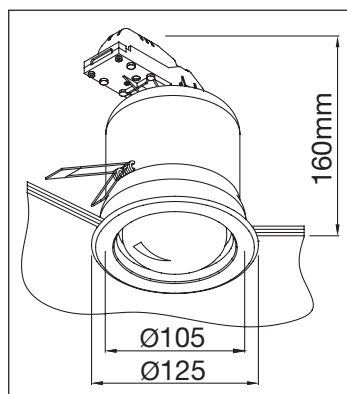

Photometrics	To Desk 1.5M	To Floor 2.4M
R80-100W <i>80 Beam Mood Lighting</i>	210 Lux 2.5 Dia	36 Lux 4.2 Dia
R80-100W <i>25 Beam Task Lighting</i>	890 Lux 0.7 Dia	320 Lux 1.1 Dia

FLUORESCENT
SBF80-13EWW

- 60 lm/W • 780 total lm
- 13Watts • 2,700K • CRI>80 • 70° Beam

LED
R80D-10EWW

- 75 lm/W • 750 total lm • Dimmable
- 10Watts • 3,000K • CRI>81 • 120° Beam

LED
R80-10EWW

- 70 lm/W • 700 total lm
- 10Watts • 3,000K • CRI>81 • 120° Beam

MODEL	CLASS	AIR / MOISTURE TRANSFER	INSULATION	F	Ø	CAVITY DEPTH	SIDE CLEARANCE
SD100	CA135	Closed	Side Abutted	Yes	105mm	180mm	25mm